

ARIZONA DRIVER

THE ENTHUSIAST'S GUIDE TO LIFE BEHIND THE WHEEL

VOLUME 4 NUMBER 3
MAY-JUNE 2005

SAY HI TO HYDROGEN
*BMW is hard at work on this
potential fuel in your future*



Also...
■ HONDA ACCORD HYBRID
■ ACURA RL SEDAN

CONTENTS

VEHICLE IMPRESSION

EQUIPMENT

TEST DRIVE

VEHICLE TECHNOLOGY

VEHICLE REVIEW

DEPARTMENTS

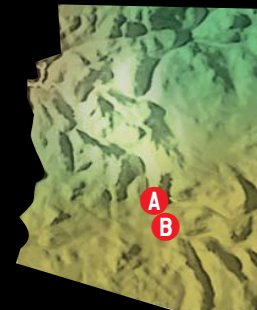

MAY-JUNE 2005

Acura RL all-wheel-drive 18

What do you get when you take Honda engineering and reliability, apply it to the upscale Acura line, completely update the vehicle for a new model year, and then add all-wheel-drive on top of all that? Sounds promising. Let's find out how this car performs.

By Joe Sage and Barbara Schaffer

GM introduces PhatNoise entertainment system 24

Have a little trouble getting everyone to agree on what to watch or listen to, or which of those, or how loud, or when or in what sequence? You may have more than a reasonable chance to restore family order with this setup.

Honda Accord Hybrid 26

When we drove the Honda Civic Hybrid and reported on it in the last issue, we found it as solid and straightforward and well-mannered as any normal Honda, begging the question, "why can't all cars do this trick?" When we posed that question to Honda, they gave a knowing look. Two months later, we received our test Accord Hybrid.

By Joe Sage, and Barbara and Bill Schaffer

Hydrogen and BMW: BMW CleanEnergy Program 30

Fuel cells, fuel cells, fuel cells. We all hear it all the time. We know there's hydrogen involved. We know our neighboring Gubernator is very interested in all this. We know there are major issues with oil supplies, pump prices, politics and pollution. It turns out we don't know that much. This report from the BMW Group will clarify a whole lot more than we knew so far.

Kia Sportage 40

Once upon a time, this was a novel little critter, a Baby Ute, as it were. It was practically alone in the marketplace, but it was well reviewed and generally pretty popular. Then it went dormant for a couple of years, even as Kia was rising in prominence domestically. Lo and behold, the Sportage has reemerged, transformed to a great degree and better than ever.

FROM THE PUBLISHER : START YOUR ENGINES 4

CAR SMARTS : QUIZ 7

AUTO NEWS UPDATE 10

MOTOR RESOURCES DIRECTORY 28

DESTINATION DIRECTORY 22

THE INSIDE TRACK: BRIEFS & RUMORS 38

UPCOMING FEATURES 42

COVER: BMW hydrogen-powered 7 Series. Photo courtesy BMW.



We check out a couple of great test vehicles this issue—the all-wheel-drive Acura RL, which proves once again that the Japanese luxury car market is very well able to keep up with the best of the Europeans in both concept and execution; and the Honda Accord Hybrid, which is exactly what we wished for after driving the Honda Civic Hybrid (see March/April 2005 *Arizona Driver Magazine*).

With hybrid technology becoming more top-of-mind with more people all the time (see information on new vehicles coming from General Motors, page 11), we of course still find plenty of other new ideas on the horizon. With that in mind, we take a look at what BMW has been up to in developing hydrogen as an automotive fuel. Hydrogen has been getting as much buzz as anything, and our neighbors in California are right on top of the curve on this one, so we might well be among the first to experience hydrogen fuel on a practical basis.

For teen drivers, we break from safety and training issues to present something GM has put together with them in mind, a PHATNOISE audio system for this year's crop of Chevy, Buick, Pontiac and Saturn minivans.

And we take a look at the Kia Sportage, one of the first baby utes in the US market (following the Mitsubishi Montero/Dodge Raider pair of a few years prior). The sometimes fine and sometimes broad lines separating sport, utility, on- and off-road continue to blur and/or mean different things to different people. Check this one out.

Enjoy the ride!



A blue ink handwritten signature of Joe Sage.

Joe Sage
Publisher/Executive Editor

ARIZONA DRIVER

MAGAZINE

PUBLISHER/EXECUTIVE EDITOR:

Joe Sage

CONTRIBUTING WRITERS:

Jill Amadio, Pilar Covarrubias,
Mark Cox, Larry Edsall,
Dan J. Gardner, Gary Goldzweig,
Bob Kroener, Jim Rogers,
Bill & Barbara Schaffer, Tim Sharp

CONTRIBUTING PHOTOGRAPHERS:

Jean-Pierre Brietta, Rich Cox,
Luis DeBonoPaula, Larry Edsall,
Dan J. Gardner, Randy Lorentzen,
Jim Pyle, Dick Reed

DESIGN & PRODUCTION: AdZoneAZ

ADVERTISING SALES: 480-948-0200

ARIZONA DRIVER MAGAZINE

PUBLISHED BIMONTHLY BY ADZONE ARIZONA LLC
Arizona Driver Magazine
PO Box 13387 - Scottsdale AZ 85267
www.azdrivermag.com

Arizona Driver Magazine and
Arizona Rider Magazine are registered
tradenames of AdZone Arizona LLC.



1. As of January 1, 2005, how many cars and trucks were in the inventories (built and available for sale) of the manufacturers and dealers in the US?
 - a. 1,588,600
 - b. 2,327,100
 - c. 3,915,700
 - d. 6,242,800
2. How much is the Ford Division planning to spend (on an average) each day for advertising in 2005?
 - a. \$500,000
 - b. \$1.5 million
 - c. \$2.5 million
 - d. \$3.5 million
3. What was the third best selling vehicle in 2004 after Ford F-Series and the Chevy Silverado?
 - a. Honda Accord
 - b. Dodge Ram
 - c. Toyota Camry
 - d. Ford Explorer
4. When did Ferry Porsche build the 356, Porsche's first sport car?
 - a. 1944
 - b. 1948
 - c. 1952
 - d. 1956
5. Which car was listed as the hottest vehicle of 2004 by *Advertising Age*?
 - a. Ford GT
 - b. Toyota Scion xB
 - c. Chrysler 300
 - d. Mazda3
6. A survey of 1000 global CEOs listed which car company as the most respected?
 - a. General Motors
 - b. BMW
 - c. Toyota
 - d. DaimlerChrysler
7. Which car received the GreenerCars.com rating as the meanest cars for the environment in 2004?
 - a. Ford Excursion
 - b. Land Rover Range Rover
 - c. Volkswagen Touareg V-10 diesel
 - d. Dodge Ram 1500 pickup
8. Which of the following has the highest percentage of US-made parts?
 - a. Ford F-Series Heritage
 - b. Lincoln Town Car
 - c. Ford Taurus
 - d. Ford Crown Victoria

9. What percentage of truck buyers in 2004 were women?
 - a. 15 percent
 - b. 24 percent
 - c. 29 percent
 - d. 37 percent
10. What's a typical peak horsepower rating of a competitive Top Fuel dragster engine?
 - a. 2,500 hp
 - b. 5,000 hp
 - c. 7,500 hp
 - d. 10,000 hp
11. How many miles of highways are there in China?
 - a. 10,500 miles
 - b. 18,500 miles
 - c. 29,500 miles
 - d. 42,500 miles
12. When did Audi first offer the quattro all-wheel drive system in the United States?
 - a. 1982
 - b. 1986
 - c. 1990
 - d. 1994
13. How many different cars and trucks were available with all-wheel drive in 2004?
 - a. 12 cars and 10 trucks
 - b. 23 cars and 26 trucks
 - c. 35 cars and 38 trucks
 - d. 44 cars and 43 trucks
14. The median age of the US passenger car fleet hit an all time high for 2004 – what was that median age?
 - a. 6.1 years
 - b. 7.4 years
 - c. 8.9 years
 - d. 9.8 years
15. How many gallons of fuel are used per minute by a Top Fuel dragster during wide-open throttle acceleration?
 - a. 7 gpm
 - b. 27 gpm
 - c. 47 gpm
 - d. 77 gpm
16. Which stock SUV recently broke the world's record for driving to the highest summit (6080 meters or 19,948 feet) and returning?
 - a. Volkswagen Touareg
 - b. Land Rover LR3
 - c. Ford Escape Hybrid
 - d. Jeep Grand Cherokee
17. How many cows does it take to provide the leather for a Mercedes-Benz interior?
 - a. 2 cows
 - b. 3 cows
 - c. 4 cows
 - d. 5 cows
18. How many people die daily on Chinese roads?
 - a. 150 die daily
 - b. 300 die daily
 - c. 450 die daily
 - d. 600 die daily
19. How many robots are being used by US auto plants?
 - a. 30,000
 - b. 50,000
 - c. 70,000
 - d. 90,000

20. What is the average age of a Scion owner?
 - a. 25-years old
 - b. 35-years old
 - c. 45-years old
 - d. 55-years old
21. Mercedes-Benz recently launched the new S65 AMG sedan with the claim that it is world's quickest four-door car. How fast does it accelerate from 0 to 60 mph?
 - a. 3.9 seconds
 - b. 4.2 seconds
 - c. 4.7 seconds
 - d. 5.1 seconds
22. A modified Porsche GT2 recently broke the world's top speed record for road-registered cars with what speed?
 - a. 222.1 mph
 - b. 234.5 mph
 - c. 241.1 mph
 - d. 253.6 mph
23. What is the world record time for a quarter mile?
 - a. 3.541 seconds
 - b. 4.441 seconds
 - c. 5.641 seconds
 - d. 6.141 seconds
24. What will be the base price of the upcoming 2006 Pontiac Solstice roadster?
 - a. \$17,995
 - b. \$19,995
 - c. \$21,995
 - d. \$23,995
25. How many Mazda Miatas have been sold in the US in the last 16 years?
 - a. 350,000
 - b. 500,000
 - c. 700,000
 - d. 950,000
26. One in every how many 16-year-old drivers will have a reportable car crash within their first year of driving?
 - a. 1 in 2
 - b. 1 in 5
 - c. 1 in 10
 - d. 1 in 20
27. What percentage of the highway traffic deaths were caused by alcohol-related accidents?
 - a. 20 percent
 - b. 30 percent
 - c. 40 percent
 - d. 50 percent
28. How long did it take MINI to sell its first 100,000 cars in the United States?
 - a. 13 months
 - b. 24 months
 - c. 35 months
 - d. 46 months
29. How many satellites does XM radio have in orbit to transmit radio programming to the US?
 - a. 2 satellites
 - b. 3 satellites
 - c. 4 satellites
 - d. 5 satellites
30. What percentage is plastic (by weight) of the average new vehicle in the US?
 - a. 3.5 percent
 - b. 7.5 percent
 - c. 10.5 percent
 - d. 15.5 percent

ANSWERS ON PAGE 8 >>

>> ANSWERS (quiz on page 7) >>

1. Answer: c. According to the *Automotive News* Data Center there were 3,915,700 cars and trucks in the inventory of dealers and manufactures in the US.
2. Answer: b. Ford plans to spend about \$550 million annually or \$1.5 million per day on advertising in 2005.
3. Answer: c. The Toyota Camry was the third best-selling vehicle of 2004 with total sales of 426,990. The F-series sold 939,511 and Silverado sales were 680,768. The Dodge Ram pickup was a close forth with 426,289.
4. Answer: b. Ferry Porsche built the first Porsche sports car in 1948.
5. Answer: c. *Advertising Age* magazine listed the Chrysler 300 as the hottest vehicle of 2004. The balance of the top 10 list included 2-Toyota Scion xB, 3-Ford GT, 4-Mazda3, 5-Audi RSQ (concept), 6-Ford Escape Hybrid, 7-Hummer H2 SUT, 8-Dodge Magnum, 9-Maserati Quattroporte, 10-Mercedes-Benz SLR McLaren.
6. Answer: c. PricewaterhouseCoopers LLP surveyed 1,000 global CEOs last year and asked them which companies they most respected. Number three on the list, after General Electric and Microsoft was Toyota. DaimlerChrysler – 13. BMW – 16. General Motors – 18.
7. Answer: c. Based on fuel economy and pollution ratings the Volkswagen Touareg CDI V-10 diesel was the meanest car to the environment in 2004. It received the lowest rating of 9. The Dodge Ram, Ford Excursion and Land Rover all received a score of 12.
8. Answer: a. Although the difference is insignificant, the Ford F-Series Heritage has 96 percent domestic content. The other three Ford products are listed at 95 percent.

9. Answer: d. According to a General Motors report 37 percent of the truck buyers in 2004 were women.

10. Answer: c. Approximate peak output, in horsepower, of a competitive 2005 Top Fuel dragster engine is 7,500, or nearly 1,000 horsepower per cylinder.

11. Answer: b. In 1989 China had only 168 miles of highways. According to *Road & Track* magazine, by the end of 2003 there were 18,500 miles of highway. In that time, China spent \$42 billion and used 40 percent of the world's cement building the roads.

12. Answer: a. Audi started selling the quattro all-wheel drive system in the United States in 1982. That year they sold 285 quattro vehicles. In the first 10 months of 2004 they have sold 50,375 quattro-equipped vehicles.

13. Answer: c. According to Edmunds.com there were 12 cars and 10 trucks with all-wheel drive or all-wheel drive options in 1999, and in 2004 that number had grown to 35 cars and 38 trucks.

14. Answer: c. The US passenger car fleet is the oldest in history with a median age of 8.9 years according to an R.L Polk survey.

15. Answer: d. According to *Motor Trend* magazine, a Top Fuel dragster burns fuel (generally nitromethane) at the rate of 77 gallons per minute. During a typical warm-up, burnout, staging and quarter-mile run, the dragster will typically burn 22.75 gallons.

16. Answer: a. In January a standard Volkswagen Touareg conquered the summit of Ojos del Salado in Chile, the world's highest volcano, to make it into the *Guinness Book of Records*. The Volkswagen reached 6080 meters or about 19,948 feet, which is the highest elevation ever recorded for a vehicle.

17. Answer: c. It takes the hides from four cows to upholster the interior of a single Mercedes-Benz.

18. Answer: d. According to the World Health Organization, more than 600 people die daily of traffic accidents in China, plus there are more than 45,000 injured daily.

19. Answer: c. According to the Robotic Industries Association of Ann Arbor, Mich., there are about 70,000 robots being used by US auto manufacturing plants.

20. Answer: b. According to Jim Press, Executive VP, Toyota Motor Sales, the average age of a Scion owner is about 35 years old.

21. Answer: b. According to Mercedes-Benz, the new S65 AMG luxury sedan, with it's six-liter twin turbocharged V-12 engine, accelerates from 0 to 60 mph in just 4.2 seconds. The engine produces 604 horsepower and 738 lb.ft. of torque, plus the car is as smooth and quiet as all the other Mercedes vehicles.

22. Answer: c. A Porsche 911 GT2-based 9F-V400 modified by German aftermarket tuner 9ff recently broke the top-speed world record for a road-registered car in January at the Nardo test track in Italy with a top speed of 241.1 mph. The previous world record of 240.1 was established in 1998 in a McLaren F1.

23. Answer: b. According to *Motor Trend* magazine the record elapsed time for a quarter mile is 4.441 seconds. It was set by Tony Schumacher's Army dragster in 2004. The speed at the end of the quarter mile was 333.08 mph.

24. Answer: b. General Motors has set the base price of the upcoming Pontiac Solstice roadster at \$19,995 including destination charge. Standard equipment includes a 177-hp 2.4-liter 4-cylinder engine, 5-speed manual transmission and 18-inch wheels. A well-equipped Solstice will sell for about \$24,000.

25. Answer: c. Mazda has sold 700,000 Miata roadsters in the United States during the last 16 years.

26. Answer: b. According to *USA Today*, 1 in 5 16-year-old drivers will have a reportable car crash within their first year of driving.

27. Answer: c. According to the National Highway Safety Administration and Mothers Against Drunk Driving, 40 percent of the highway fatalities in 2004 were a result of alcohol related crashes.

28. Answer: c. When BMW started selling the MINI in the US in March 2002, they expected to sell about 20,000 annually. In 2004 36,032 Minis were sold and they reached the 100,000 mark in February 2005, or in just 35 months.

29. Answer: b. In February 2005 XM launched XM-3, its third satellite to transmit radio programming to the US. The other two satellites were launched in 2001. XM-3 was built by Boeing satellite Systems International Inc. at a cost of \$250 million, including the launch.

30. Answer: b. According to The Ecology Center, an advocacy group in Ann Arbor, Mich., and Clean Production Action of Spring Brook, N.Y. about 7.5 percent of cars, on average, by weight are plastic. ■

The Car Smarts quiz includes news and trivia from industry sources, trade journals and consumer magazines compiled for *Arizona Driver* by **BILL & BARBARA SCHAFFER** of *Auto Digest*.



CADILLAC HIGH PERFORMANCE STS-V

Cadillac expects the new STS-V to compete directly with Europe's famous sport sedans. Powered by the first supercharged Northstar V-8 engine, the STS-V will boast 440 horsepower and 430 lb.ft. of torque, pushing the rear wheels through GM's first six-speed automatic transmission. Performance specs include a 0 to 60 mph time of less than 5 seconds, a top speed over 165 mph and a lap time around Germany's Nürburgring racetrack at least equal to the BMW 5-series. A polished stainless steel wire mesh grille with recessed Cadillac emblem, a restyled front fascia and ground clearance lowered by 50 millimeters (almost exactly 2 inches) will distinguish the V-Series. Although no price has been announced, the STS-V is expected to have a sticker price near \$80,000 when it reaches dealers as a 2006 model. ▼



Cadillac STS-V



Suzuki Concept-X

Suzuki, long a titan in the motorcycle world, seeks to make its mark in the automotive world. If the Concept X is any indication, they will be noticed.

VOLVO WILL BUILD A SMALLER CAR

Volvo has confirmed it will build car one size smaller than the current S40 sedan. The three-door fastback coupe will be called the C30 and it is scheduled to arrive in late 2006. The C30 will hold either four adults or two adults and three kids. It will be based on the current S40 platform but will be about 8 inches shorter. The power will come from the same four-cylinder engine that powers the S40. The rear end of the C40 is said to resemble the P1800 coupe from the 1960s.

SUZUKI MID-SIZE SUV CONCEPT-X

▲ Suzuki is showing a Concept-X SUV that will be the basis for a new mid-size SUV to be sold in 2006. The sleek, wedge-shaped wagon has a four-wheel drive system called "4GO", which combines on-demand low-range ability with typical all-wheel drive efficiency. The concept is fitted with sophisticated entertainment and information technology that includes satellite television/DVD/DVR player and dual 12-inch LCD screens mounted for viewing for the second and third row seats. It also has integrated Bluetooth technology for cellular phones, PDAs, e-mail and navigation. Advanced safety

technology features curtain airbags for all six passengers, dual heat-sensing perimeter CCD cameras to warn the driver of objects in the vehicle's proximity. It also has an automatic 911 calling system that calls for help when the airbag deploys plus an active cruise control system. Not all the advanced technology will likely end up in the production model.

GM WILL OFFER HYBRIDS BY 2007

General Motors plans to offer "full mode" hybrid versions of the Chevrolet Tahoe and GMC Yukon by 2007. Tom Stephens, group vice president of GM powertrain, confirmed GM has secured key patents that allow them to scale the system to multiple configurations. The full-hybrid architecture will allow the system to work with rear- and front-drive packages along with gasoline or diesel engines. When these technologies are combined with cylinder deactivation the engines are expected deliver up to 25 percent better fuel efficiency. According to Automotive News the system uses two electronically controlled motors on a series of gears to create a variable drive system. The entire system fits in the same space as a conventional automatic transmission.

The system will be able to operate in the electric only mode under light load situations or with gas and electrical during increased load demand.

RESEARCHERS ELIMINATE CAR ODORS

German researchers at Siemens VDO Automotive are developing a technology that will allow carmakers to build cars that will eliminate virtually any unpleasant smells in the interior of the car. By combining existing technology with some new devices they are able to automatically control the quality of air inside the vehicle including the temperature, humidity, CO2 level and even smell. This would mean no more smell from farms, smoke, hot road tar, or even foul smelling passengers. The sensors would activate filters and recirculation systems when the scent is detected to automatically eliminate the smell. No timetable for the introduction of the technology was mentioned.

GM LATEST SAFETY INITIATIVE

General Motors announced it will equip all new cars and trucks, except for some commercial and fleet vehicles, with the

KEEP RIGHT >>

MERCEDES DEBUTS LUXURY R-CLASS

Combining the advantages of a four-wheel-drive sport utility, the comfort of a sport sedan and the versatility of a luxury wagon, the new Mercedes-Benz R-Class creates a new niche vehicle. The R350, which goes on sale later in 2005, has a 268-hp, 3.5-liter V-6 engine with a seven-speed transmission and full-time 4MATIC four-wheel drive. A 5.0-liter 302-hp V-8 will power the upper level R500 version. The sleek wagon-style R-Class sits six adults in three rows of two single seats. The size is about five-inches longer than the Cadillac Escalade and 10 inches longer than a Cadillac SRX. Engineers have eliminated the console-mounted shifter and replaced it with a small stock on the steering column – to shift, lift up for reverse, down for drive and push a button for park. Once underway, pushing one of the shift buttons on either side of the steering wheel provides Touch Shift manual gear changes. ▼



Mercedes-Benz R-500

Volkswagen Passat



Meeting the new Audi grille treatment halfway, the new Passat represents a major evolution for Volkswagen, as size and performance continue to grow.

>> AUTO NEWS UPDATE - cont'd

company's highly touted OnStar communications and StabiliTrak electronic stability control. The OnStar communications system allows someone in the vehicle to connect directly with a live person to obtain help finding directions, unlocking a vehicle (when the keys are locked in), tracking a stolen vehicle and alerting emergency services when the air bags deploy. The StabiliTrak system helps a driver maintain vehicle control during challenging or unexpected driving conditions such as ice, snow, wet pavement, emergency lane changes or avoidance maneuvers. The expansion to the entire product line will be completed in 2007.

UDI BUMPS UP A4 EQUIPMENT LEVEL

In an effort to distance the new generation A4 sedan from the upcoming less expensive A3, Audi has bumped up the content, power and price of the A4. Standard on the all-new A4 is a sport steering wheel, a new electronic stability control system as well as antilock brakes. The standard engine is now a 200-hp 2.0-liter turbo with a six-speed manual or continuously variable transmission and

front wheel drive. The quattro all-wheel drive cars will be either a six-speed manual or automatic. The V-6 engine will be the same 3.2-liter direct-injection V-6 (255-hp) as is used in the A6. Beginning prices will range from \$28,070 for the 4-cylinder to \$36,120 for the V-6 as compared with the entry level A3 that will start around \$25,000. The high-performance S4 will arrive in May with power coming from a 340-hp 4.2-liter V-8. A 420-hp RS4 is scheduled for mid-2006.

NEW VW PASSAT DEBUTS AT GENEVA

▲ Volkswagen threw a coming out party for the all-new sixth-generation Passat sedan at the Geneva auto show. The flagship Volkswagen is much larger than the previous model and shares no platform elements with the previous generation, the Audi or even the Volkswagen-owned Skoda. The engine is a new 3.6-liter V-6 derived from the previous 3.2-liter engine. The transversely mounted engine will be exclusive to North America and will produce 280 horsepower. The other engine choice is a 2.0-liter turbo four-cylinder. Buyers will have a choice of a six-speed automatic or manual transmission and an optional all-wheel drive system. A wagon version will

be available in mid-2006, while the sedan goes on sale this summer.

DRIVING HABITS AND INSURANCE

A British insurance company is testing the use of GPS receivers in the trunks of vehicles to monitor driving habits. Norwich Union Insurance has installed the systems in 5,000 vehicles and used the data accumulated to adjust driver's premiums from month to month. The system collects data on speed, acceleration, braking, etc. to establish the rates. So far the company has collected data on about 1 million journeys to recalculate its insurance tables. Next year the company plans to make the technology available to the rest of its 3.5 million auto customers in hopes of making them safer drivers. Project manager Robert Ledger says, "Over time, we think we can change people's behavior and make them safer drivers."

DODGE ADDS MEGA CAB RAM

For the 2006 model year Dodge will offer a Mega cab version of its big Ram truck making it the largest passenger compartment available on any pickup.

KEEP RIGHT >>

BUICK SHOOTS HIGH WITH LUCERNE

Buick's new full-size Lucerne, which replaces the LeSabre, will not only move the model into the entry-luxury level, but it will offer a new more angular styling. The Lucerne will also be the first Buick to use the General Motors Magnetic Ride Control, a suspension system that used magnetically charged particles suspended in a fluid, which changes continuously to adapt to road conditions. Standard power for the new front-drive Buick is a 3.8-liter V-6, but the big news is the new optional 4.6-liter, 275-hp V-8. The Lucerne will be the first Buick to have a V-8 engine in 10 years. ▼



Buick Lucerne



Viper Coupe



Maybe it's for the added rigidity, perhaps just to run racing stripes front to rear with a roof... either way, the Viper Coupe fills a major need for drivers.

>> AUTO NEWS UPDATE - cont'd

The rear door opening will be an industry-leading 34.5 inches. The rear seats will recline as much as 37 degrees (another industry first), and the seat back can be split 60/40 for reclining or flat for cargo. There is an additional 7.6 cubic feet of cargo space behind the rear set inside the passenger compartment, making enough room for several small pieces of luggage. The Mega cab rides on a 160.5-inch wheelbase, but engineers have cut the 8-foot box to 6-feet 3-inches for additional cab space. The Mega cab will be available on the 1500, 2500 and 3500 series trucks starting this fall. New options include a navigation system, rear-seat DVD player, power sliding rear window, heated front seats, power sunroof and adjustable pedals.

THE VIPER COUPE IS BACK

▲ Dodge is bringing back the Viper Coupe for the 2006 model year. When the second generation Viper appeared in 2003 Dodge dropped the coupe version. But now with pressure from current Viper owners and Chevrolet challenging with the Corvette Z06, Dodge felt that it was time to bring back the coupe. It will

have a 500-hp V-10 engine capable of 4.0-second 0 to 60 mph acceleration times. Braking from 60 mph is less than 100 ft, making it one of the best stopping cars ever.

LAND ROVER HAS AMBITIOUS PLANS

Land Rover's major product overhaul started last year with the introduction of the impressive new LR3 replacing the Discovery. The LR3 took design cues from the flagship Range Rover, V-8 power from the Jaguar sedan and married them with one of the industry's most sophisticated drive and suspension systems. Later this year the updated Range Rover and high performance Range Rover Sport will arrive with new Jaguar V-8 engines and a supercharged version in the Sport. For 2006 the Freelander gets a total remake with much of the underpinnings and powertrain coming for the upcoming Volvo XC50. It is expected to be stiffer, more powerful and safer than the current model. By 2008 the off-road brand is expected to get a baby Freelander that could even be available in front wheel drive - a first for the four-wheel drive exclusive company - which could be aimed at raising company CAFÉ fuel economy ratings.

A CORVETTE C6 Z06

As if the new 400-hp, 186-mph C6 Corvette wasn't fast enough, Chevrolet engineers are upping the performance ante with the new Z06. With 100 fewer pounds and 100 hp more, the Z06 clearly has its sites on cars like the Porsche 911 Turbo. According to Chevrolet engineers the Z06 should make the yardstick 0 to 60 mph run in less than 4 seconds, the 0 to 100 mph in less than 8.0 seconds and on to a top speed of more than 190 mph. Power comes from a new highly modified 7.0-liter small-block aluminum V-8 engine. The body gets better aerodynamics and some reshaping. The interior is modified to trim weight, and improve driver agility, while adding a long list of standard equipment like Bose audio, head-up display and navigation. With an estimated \$70,000 price tag, the Z06 Corvette could be the supercar buy of the century.

MERCEDES SWAPS E-CLASS ENGINES

Mercedes-Benz has replaced the 3.2-liter in-line 6-cylinder engine in the E-Class sedan with a new 3.5-liter V-6 engine that produces 20 percent more power than

KEEP RIGHT >>

SAGE

ADVERTISING

DESIGN

PUBLISHING



Brochures / Catalogs / Magazines

Concept / Design / Production / Print Publishing
Media Planning & Placement

Call to discuss individual projects or strategic needs.

AUTOMOTIVE / AVIATION / BOATING
MANUFACTURERS / IMPORTERS
INDUSTRIAL / CONSTRUCTION
TOURISM / ACTIVITIES / EVENTS
RESORT / HOTEL / LODGING
INSTITUTIONAL / FINANCIAL
REAL ESTATE / DEVELOPMENT

480-948-0200

ADZONE ARIZONA LLC

>> AUTO NEWS UPDATE - cont'd

the previous engine. The new DOHC V-6 has an aluminum block, cylinder heads and other lightweight parts, to help deliver silky-smooth performance. The engine is rated at 268-hp and 258 lb.ft. of torque. It also has a standard 7-speed automatic transmission that helps push the base model sedan from 0 to 60 mph in less than 7 seconds and to a top speed limited to 155 mph. The 4Matic all-wheel drive version will retain the current 5-speed automatic.

CADILLAC CTS: REAL-TIME TRAFFIC INFO

Cadillac has started shipping CTS models equipped with an optional XM NavTraffic™ system. It's the nation's first real-time satellite traffic information service to provide continually updated traffic information in 20 major metropolitan areas. The new technology is available exclusively from XM Satellite Radio and is powered by NAVTEQTraffic™. Drivers can enter a destination into the navigation system, and then, aided by a color-coded display, obtain instant traffic data on the preferred route. The system will display current information about traffic incidents and average traffic speed along specific roadways.

FORD ADDS ADRENALIN TO SPORT TRAC

Ford plans to produce its first high performance Sport Utility Truck (SUT) starting 2007. Called the Adrenalin, the new performance segment vehicle will marry the best attributes of the SVT F-150 Lightning and the Ford Explorer Sport Trac. Power will come from a 4.6-liter 390-hp supercharged V-8 engine driving through a heavy-duty six-speed automatic to the full-time all-wheel drive system. It will also include Ford's AdvanceTrac® and Roll Stability Control™. The Adrenalin will have four-wheel independent suspension and will ride on 21-inch wheels and tires. Unlike some high performance trucks, the Adrenalin will have a 5,000-pound towing capacity.

XM UPS MONTHLY RATE

XM Satellite Radio Inc. has raised the monthly service charge from \$9.99 per month to \$12.95 per month to match the rate of its only competitor Sirius Satellite Radio Inc. XM currently has 3.3 million

subscribers and expects to grow to 5.5 million by the end of the year according to Automotive News. XM said it subscribers can lock in the current rate by paying in advance as much as five years. XM also is moving some of the premium channels into the basic lineup and dropping the extra charge to listen to broadcasts via the Internet.

GENERATION II MERCEDES M-CLASS

The second generation Mercedes-Benz M-Class, which goes on sale this spring is longer, wider and lower than the original. The new model resembles the previous model but is characterized by an aggressive wedge shape with sweeping front fenders, dramatic shoulder lines and a sharply angled windshield. It's arriving on an all-new unibody platform with a double-wishbone front suspension and new four-link rear suspension. It's available with two engines, a new 3.5-liter four-valve 268-hp V-6 or a 302-hp 5-liter V-8. Both engines come with the new Mercedes 7-speed automatic transmission and a more effective permanent 4-wheel drive system. It also has an optional height adjustable air-suspension. The four-wheel drive traction control system now incorporates functions such as a downhill driving aid and hill-start assist. The interior is all new with more room for all five occupants.

MAZDA IS PHASING OUT "MIATA"

As Mazda rolls out the redesigned 2006 Miata sports car, the new version will be badged MX-5. The popular two-seater has always been named the MX-5, but it was always referred to as the Miata both in marketing and on the rear of the car. The new model will drop the Miata designation in favor of the MX-5 badge, but the name will continue to be used in marketing and PR materials. The plan is to eventually eliminate the Miata name altogether.

CHEVROLET EXPANDING SS LINE

Chevrolet will add three more SS performance models to their 2006 model year lineup by the end of this year. First out of the chute will be an SS version of the TrailBlazer SUV, which is infused with a 6.0-liter 391 horsepower Corvette-based V-8 engine. Chevrolet says the TrailBlazer SS will go from 0 to 60 mph in 5.7-seconds. It comes with a performance suspension, 20-inch wheels and



Jeep Gladiator concept

Jeep has produced amazing concepts recently, and many have made it to market in some form.

cosmetic enhancements.

Other new models include SS versions of the Malibu and Malibu Maxx. A 240-hp 3.9-liter V-6 engine with variable valve timing will power both models. Other enhancements include 18-inch wheels and a sport-tuned suspension.

JEEP PICKUP CONCEPT

▲ Jeep may be getting back into the pickup business if they produce the Gladiator concept shown recently. The Gladiator resembles a truck version of the Jeep Wrangler and Liberty sport utilities. It is about the same size as the midsize Dodge Dakota pickup and is powered by a 2.8-liter, four-cylinder, 163-horsepower, 295-lb.ft. turbodiesel engine with a part-time four-wheel drive. The Gladiator has an extended cab with a lower access door on the driver side and a full-height rear-hinged door on the passenger side. The spare tire is mounted on the side like some earlier Jeep pickup models. The concept has a canvas top and a rear window that rolls down. The rear seat cushion drops and slides under the deep

bed, which then slides forward to extend the bed length from 5.6 feet to a full 8 feet. Jeep has not announced plans to build the Gladiator, but it appears that it would be an easy product to integrate into the Jeep lineup.

AUDI IMAGE CAR IN WORKS

Audi boss, Martin Winterkorn, said at a Geneva Auto Show, that the company will probably build a super car based on the Le Mans quattro concept that debuted at the 2003 Frankfurt auto show. The Le Mans concept was powered by a 610-hp 5.0-liter twin turbo V-10. The car was developed from the Lamborghini Gallardo architecture. (Both Audi and Lamborghini are Volkswagen owned brands.) Winterkorn said it will be among several niche vehicles Audi plans to introduce to fill out its product lineup so that it can better compete with brands like BMW and Mercedes-Benz. ■

Auto News Update includes a summary of auto news from industry sources, trade journals and consumer magazines compiled for *Arizona Driver* by **BILL & BARBARA SCHAFFER** of *Auto Digest*.

Acura/Honda Confidence Meets All-wheel-drive Confidence

By Joe Sage
and Barbara Schaffer



It's hard not to be a fan of Honda (and therefore Acura), with their reliability, immediacy to market, family-owned focus, engineering prowess and general git-er-done success. But what if you're not a fan of front-wheel drive? Aside from the Honda S2000 2-seater, there's precious little in the Honda lineup for you (at least in rear-drive configuration; there are always the SUVs in 4x4 dress). Until now. When the Japanese first entered the luxury market, Acura did little to reengineer from their Honda basis. Infiniti has had a rear-wheel emphasis since the beginning. And Lexus has gone 'round the track with both approaches. Enter the end-run solution: Honda brings us the Acura RL, restyled and with gadgets and features galore, but also with an all-wheel-drive system. Let's see how the package works.

KEEP RIGHT >>



■ The 3.5-liter VTEC V-6 engine provides 300hp to the Acura RL's SH-AWD all-wheel-drive system.

■ Thoughtful features like rear-view mirror turn indicators provide both safety and style.



■ It always feels good to sit in an Acura. Style and comfort are tops, while the cockpit remains clean and gets straight down to business. Controls are complete, well-placed and intuitive. Even the navigation and function screen is welcome on this machine, simple and unobtrusive.



■ Back seat room is quite comfortable, even for a business group of four, with overall vehicle size still very manageable.

■ Keyless ignition is a matter of personal taste. Since you only need the key in proximity, be careful not to rest it on the console and then perhaps lock yourself out.

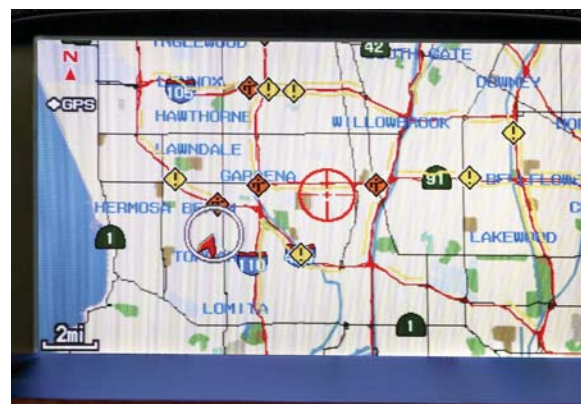

■ Not everyone wants or needs a navigation screen or an information center on their console, whether for reasons of distraction, complexity or both. But we found the Acura system to be intuitive and quick to learn. Day/night white/black backgrounds work well. And a wealth of information is at your fingertips with the system.

■ The SH-AWD system is as well-engineered as anything from Honda's engineers, and the proof is in the capable all-surface confidence of the new Acura RL.

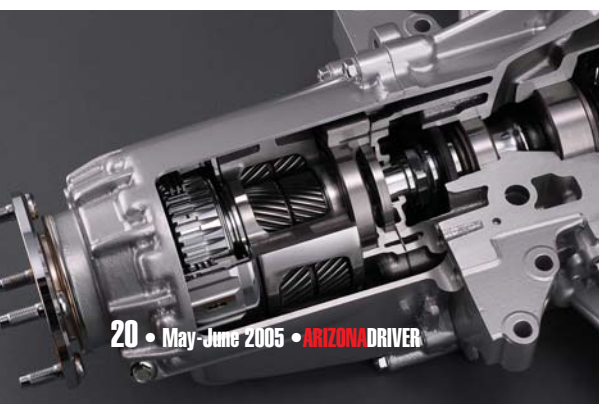

Acura RL

By Barbara Schaffer

The exciting all-new Acura RL is loaded with new amenities and new technology. And if RL doesn't stand for "really luxurious," it should!

As part of the RL introduction, Acura has us drive 90 miles to the Summit Point Raceway in West Virginia, where we had the opportunity to put the RL through its paces. Both the highway and track driving had an extra degree of difficulty, thanks to aftermath of Hurricane Jeanne that was still dowsing the area. We also had a chance to compare the RL to its competitors. The new all-wheel-drive RL outperformed them all, except for the Mercedes 4-matic, which performed equally as well but costs several thousand dollars more.

The new design of the Acura RL is good-looking but conservative, which for many consumers is a good thing. The sloping hood angles down to an aggressive front fascia and the signature five-sided grille. The exterior of the RL has simple lines and is almost three inches shorter and more than an inch wider than the current version, but offers more passenger volume.

Inside the cockpit there's a sporty but luxurious atmosphere with rich leather, genuine wood trim and an abundance of leading-edge technologies including standard real-time traffic information. This system is linked to AcuraLink™, offering up-to-the-minute traffic information (where

available) on traffic speeds, accidents and freeway construction, displayed on a large eight-inch screen. This system also allows for communication between Acura and the vehicle, providing customers with the latest diagnostic information specific to their vehicle. Because it works with the car's HandFreeLink™ wireless phone interface, drivers can respond to messages on one-touch-dial to dealers and Acura Roadside Assistant using their Bluetooth phone.

Another standard feature is the Acura Navigation System with Voice Recognition™, which has a menu of 560 voice commands and a destination guide to over 7 million points of interest, all with 3-D graphics. Of course, that's nearly the equivalent of learning a foreign language.

Remember, all these incredible new technologies come as standard equipment and along with Xenon headlights, Bose® sound system with CD, DVD audio & DTS™ changer, OnStar® communications system, power moonroof and all the usual amenities for a \$49,470 price tag. The only options are a choice of nine exterior and three interior colors. A 3.5-liter VTEC V-6 engine with 300 horsepower and 260 lb. ft. of torque powers the new Acura RL. This is paired to a five-speed automatic transmission with Sequential SportShift with steering wheel-mounted paddle shifters and GradeLogic Control. ■

BARBARA SCHAFFER is co-editor of *Auto Digest* reviews, rumors and other features.

Acura RL

STANDARD EQUIPMENT:

Vehicle Stability Assist; Xenon headlights; Keyless Access System; Perforated leather seats; Power and heated front seats; curly maple trim; AcuraLink™ satellite communication with rear time traffic; HandsFreeLink™ wireless telephone link; Navigation with Voice Recognition; Bose® audio with 6-disc CD/DVD-Audio and DTS changer; XM Satellite Radio; Active Noise Cancellation; OnStar communications system; Moon roof; Electric tilt and telescoping wheel; etc.

Base Price: \$49,470
Options: none
Freight.....\$615
Price as Tested.....\$50,085

DIMENSIONS

EPA SizeMid-size
Weight.....4,012 lb.
Wheelbase110.2 in.
Length.....193.6 in.
Width.....72.7 in.
Height57.1 in.
Fuel Capacity19.4 gal.
Cargo Capacity.....13.1 cu. ft.

MECHANICAL

Engine.....3.5L VTEC V-6
Horsepower290@6200
Torque256@5000
Transmission5-Spd. Auto
Drive.....Four wheel
Brakes.....Disc ABS
Tires.....245/680R Run Flat

PERFORMANCE

0 to 60 mph.....6.7 sec.
Top speed130 mph
EPA economy rating18/26 mpg
Our actual fuel econ24.3 mpg

COMPETITORS

Audi A6, BMW 5 Series, Cadillac STS, Infiniti M, Jaguar S-Type, Lexus GS, Mercedes-Benz E-Class, Volvo S80

Arizona

ATTRACTIONS & EVENTS

Chiricahua State Park

HCR 2, Box 6500 • Willcox AZ 85643
520-824-3560

Grand Canyon National Park

PO Box 129 • Grand Canyon AZ 86023
923-638-7888 Visitor Info Recorded Message

Lake Havasu State Park

699 London Bridge Dr. • Lake Havasu AZ 86403
928-855-2784

Organ Pipe Cactus National Monument

10 Organ Pipe Drive • Ajo AZ 85321-9626
520-387-6849 Visitor Information

Petrified Forest National Park

PO Box 2217
Petrified Forest National Park AZ 86028
928-524-66228 Visitor Information

Saguaro National Park

3693 South Old Spanish Trail
520-733-5153 Visitor Info Rincon Mtn District

Sport Compact Drag Racing

Every thursday at Firebird Raceway
www.dragracing.com/phx

Wupatki National Monument

Flagstaff Area National Monuments
6400 N. Hwy 89 • Flagstaff AZ 86004
928-679-2365 Visitor Information
928-526-1157 Visitor Information, HQ

California

ATTRACTIONS & EVENTS

Palm Desert Visitor Information Center

72-990 Highway 111 • Palm Desert CA 92260
800-873-2428 • www.palm-desert.org

MOTOR MUSEUMS

Petersen Automotive Museum

6060 Wilshire Blvd. (at Fairfax) • LA CA 90036
323-930-CARS • www.petersen.org

Colorado

ATTRACTIONS & EVENTS

Colorado Activity Centers, Inc.

737 N. Tenmile Drive - Suite 35
PO Box 129 • Frisco CO 80443
800-777-8642 - www.coloradoinfo.com

MOTOR MUSEUMS

Shelby American Collection

5020 Chaparral Court
PO Box 19228 • Boulder CO 80308-2228
www.shelbyamericancollection.org
303-516-9565

Nevada

ATTRACTIONS & EVENTS

Las Vegas Tourism Bureau

6120 W. Tropicana Ave. • Las Vegas NV
www.lasvegastourism.com

MOTOR MUSEUMS

Imperial Palace Auto Collections

Fifth floor parking facility of Imperial Palace.
702-794-3174
www.imperialpalace.com/auto.html

National Automobile Museum

The Harrah Collection
10 Lake Street South • Reno NV 89501
775-333-9300 • www.automuseum.org

New Mexico

ATTRACTIONS & EVENTS

New Mexico Department of Tourism

800-733-6396 x 0643 • www.newmexico.org

Santa Fe Chamber of Commerce

PO Box 1928 • Santa Fe NM 87504
8380 Cerrillos Rd. Suite 302 • Santa Fe NM 87507
505-983-7317 • www.santafechamber.com

RESORTS / LODGING

Inn on La Loma Plaza

315 Ranchitos Road • Box 4159 • Taos NM 87571
800-530-3040 • www.VacationTaos.com

Inn on the Alameda

303 East Alameda • Santa Fe NM 87501
505-984-21221 • www.innonthealameda.com

Utah

ATTRACTIONS & EVENTS

San Juan County Tourism

117 S. Main Street • Monticello UT 84535
800-574-4386 • www.southeastutah.org

Southern Utah Scenic Tours

PO Box 1113 • Cedar City UT 84720
888-404-8687 • www.utahscenicstours.com

RESORTS / LODGING

Desert Rose Inn & Cabins

701 W. Highway 191 • Bluff UT 84512
888-475-7673 • www.DesertRoseInn.com

Mexico

RESORTS / LODGING

Puerto Peñasco Mexico Online

Beachfront home rentals in Rocky Point.
623-935-0507 • www.puerto-penasco.com

ATTRACTIONS & EVENTS

Baja California State Tourism Office

Blvd. Diaz Ordaz s/n
Edificio Plaza Patria Nivel 3
CP 22400 Tijuana BC
(66) 81-9492

Chihuahua State Tourism Office

Calle Libertad No. 1300
Edificio Agustin Melgar, 1er Piso
CP 31000 Chihuahua, Chihuahua
(14) 29-3421

Sinaloa State Tourism Office

Av. Camarón Sabalo esq. Tiburon
Edificio Banrural 4 Piso
CP 82100 Mazatlán, Sinaloa
(69) 16-5160

Sonora State Tourism Office

Centro de Gobierno
Edificio Estatal Norte 3er Nivel
Comonfort y Paseo Río
CP 83280 Hermosillo, Sonora
(62) 17-0076

Of national interest

MOTOR MUSEUMS

Henry Ford Museum & Greenfield Village

20900 Oakwood Blvd. • Dearborn MI 48124
www.hfmgv.com • 313-271-1620

Imperial Palace Auto Collections

(see Nevada listings)

Motorcycle Hall of Fame Museum

Pickerington OH 43147
www.motorcyclemuseum.org • 614-856-2222

National Automobile Museum

(see Nevada listings)

National Corvette Museum

350 Corvette Drive • Bowling Green KY 42101
www.corvettemuseum.com • 800-53VETTE

Petersen Automotive Museum

(see California listings)

Shelby American Collection

(see Colorado listings)

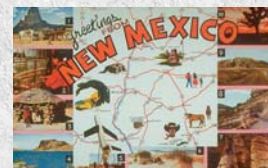

Information is derived from a variety of sources and may not be final or accurate; check all info. Listings do not necessarily represent any specific affiliation with nor endorsement by *Arizona Driver* magazine.





PHATNOISE

Chevrolet is including a new PhatNoise entertainment system as standard equipment on the 2006 Uplander AWD crossover vehicle (\$29,455). The entertainment system uses a wallet-sized 40-gigabyte portable hard drive cartridge installed in the Uplander's integrated overhead rail system. The system is capable of storing and playing back up to 40 movies or 10,000 songs or combinations thereof. It can also be used to play video games with a wireless game controller or for listening to recorded books, magazines or newspaper articles. Passengers can select up to three sources of entertainment simultaneously. For example a young child could be watching a cartoon, while a teenager listens to a custom-playlist and the parents are listening to XM Satellite Radio. The hard drive cartridge is easily removed and connected to a home PC or laptop to download customized content for playback in the vehicle. PhatNoise will be available soon on the Buick Terraza, Saturn Relay and Pontiac Montana SV6. ■



Delivering the driver's edge to teen drivers.

Traditional driver's education has focused on the skills needed to pass a driving test, with classroom lectures and some behind-the-wheel "on-the-job training." The DrivingMBA™ program goes beyond this, bringing high-tech simulators to everyday drivers.



The DrivingMBA™ Comprehensive Driving Tutoring Program

These components are available as a discounted package or individually:

- **Rules of the Road® DVD** : Award-winning interactive DVD tutorial for home use.
- **Pre-Permit Driving Simulation Course** : 5 hours total computer simulated driving experience gives teens a solid foundation in fundamentals before they get behind the wheel.
- **Safe Young Drivers** : A book to supplement your own in-vehicle training.
- **Advanced Decision Skill Building** : The same high-end simulator used by police and other professionals to improve behind-the-wheel decision-making skills.
- **Profiler™** : Assesses your skills against a pro database (included with Advanced Decision Skill Building).
- **DUI** : Students in both simulator courses experience the negative impact upon vehicle control of driving while impaired.



A PROGRAM OF ACCELERATED SKILL BUILDERS

www.drivingmba.com

9181 E. BELL ROAD, SUITE 103 • SCOTTSDALE AZ 85260 • 480-948-1648



For our next trick...

By Joe Sage and Barbara and Bill Schaffer

When we drove the Honda Civic Hybrid just a couple of months ago (see Arizona Driver, March/April 2005), we found the whole experience so stupefyingly simple and satisfying, our only question was "why can't every car do this?!" Then—when we happened to have lunch the first day of our test week with Honda reps and press fleet people—our only other question was, "why don't you make an Accord Hybrid?" Wow. We didn't know we had that much pull! The Honda Accord Hybrid pulled into our parking lot just two months later.



Honda Accord Hybrid: the bionic car

In addition to all the latest hybrid technology, the Honda Accord Hybrid uses a variable assist power rack-and-pinion steering system powered by an all-electric hydraulic pump to improve efficiency and fuel economy.

In the classic television show "The Six Million Dollar Man," ace test pilot Steve Austin's ship crashed and he was nearly dead. Deciding that "we have the technology to rebuild this man," the government decided to fix Austin, augmenting him with cybernetic parts to create the world's first bionic man.

Although the Accord already started out plenty fit, Honda's quest to make their vehicles better, faster and more efficient has led them to creating something like a bionic Accord—they call it the Accord Hybrid. We're sure it cost much more than \$6 million to develop the bionic Accord, but the results are exciting—not only is the Accord Hybrid much more fuel efficient, it's also significantly faster than the standard Accord.

Unless you recognize the different grille and rear-deck spoiler, there is no way to identify this Accord as a hybrid unless you read the word "hybrid" on the back.

The interior, however, is a dead giveaway. An exclusive meter display on the instrument panel shows key operating indicators of the IMA (Integrated Motor Assist) system, including the state of the IMA battery charge, the level of IMA motor assist or charge, and a light to indicate idle stop mode. There is also

an "ECO" light to indicate that the vehicle is achieving a high level of fuel economy and the VCM (Variable Cylinder Management) is operating in 3-cylinder mode. The VCM automatically shuts off three of the six cylinders when the vehicle is in a cruise or light load mode.

A 3.0-liter i-VTEC V-6 powers the Hybrid, with the assistance a 12 kW/16-hp electric motor. The combination engine and motor produces a total 255 hp and about a 10 percent increase in torque over the stock V-6 Accord. The net performance improvement is about three-tenths of a second from 0 to 60 mph, and fuel economy is rated at 29 mpg for city driving and 37 mpg on the highway. That's even better than the 4-cylinder Accord with automatic transmission, which is rated at 24 mpg city and 34 mpg highway. Our actual combined fuel economy averaged 31.3 mpg.

Interior features and amenities are not sacrificed because it is a hybrid. This car comes equipped with standard Honda Navigation System with Voice Recognition, leather-trimmed seats, AM/FM/6-disc in-dash audio system, XM satellite radio, 8-way driver's seat with lumbar, heated front seats, cruise control, power windows/door locks/outside mirrors, HomeLink system, a leather-wrapped steering wheel that tilts and telescopes, exterior temperature gauge plus much more for \$32,505, which is around \$4,000 more than the equivalent gasoline version.

The fuel economy improvements come from a variety of sources. Over half are a result of the Integrated Motor Assist system, with the idle stop system, improved aerodynamics and Variable Cylinder Manage-

Honda Accord Hybrid

STANDARD EQUIPMENT

Electronic Brake Distribution; Traction control; Keyless entry; Navigation system with Voice Recognition, Leather trimmed seats, AM/FM stereo with 6-disc in-dash CD changer; XM satellite radio; Dual-zone automatic climate control; Driver's 8-way power seat; Heated front seats; Power windows and locks; Tilt & telescoping steering columns; Cruise control; HomeLink system; 16-Inch alloy wheels; Rear spoiler.

Base Price: \$31,990
Options:none
Freight.....\$515
Price as Tested.....\$32,505

DIMENSIONS

EPA SizeMidsize
Weight.....3,501 lb.
Wheelbase107.9 in.
Length.....189.5 in.
Width.....71.5 in.
Height.....57.1 in.
Fuel Capacity17.1 gal.
Cargo Capacity.....11.2 cu. ft.

MECHANICAL

Engine.....3.0L SOHC V-6
Electric.....12kW – 144 volt
Gas Horsepower.....255@6000
Gas Torque.....232@5000
Electric Horsepower.....16@840
Gas Torque.....100@840
Transmission.....5-Spd. Auto
Drive.....Front wheel
Brakes.....Disc ABS
Tires.....215/60R16

PERFORMANCE

0 to 60 mph.....6.7 sec.
Top speed.....112 mph
EPA economy rating.....29/37 mpg
Our actual fuel econ.....31.3 mpg

HYBRID COMPETITORS

Ford Escape Hybrid, Honda Insight, Honda Civic Hybrid, Toyota Prius Hybrid, Toyota Highlander Hybrid, Lexus RX 400h.

KEEP RIGHT >>

Performance Tires & Wheels

Tirexchange, Inc.

Tires • Wheels • Chrome Plating
15485 N. 84th Street • Scottsdale
1-800-766-2588 • 480-596-9655

Driver Tutoring

DrivingMBA™

Comprehensive simulator tutoring for teens
A program of Accelerated Skill Builders
480-948-1648 • www.drivingmba.com

Custom Garage Interiors

GarageTek

Call to visit our completely furnished garages
623-580-0900 • www.garagetek.com

Mobile Communications

NEXT Technologies, LLC

Integrated Mobile Media Environment (IMME)
602-370-0098 • www.NextTech.biz

Mobile Broadband Internet

Sunangel Communications, Inc.

2-Way Mobile Broadband Internet
480-905-1663 • www.broadbandonwheels.com

Mobile Detailing Service

Waxwerks Detailing

Detailing - Valley Wide Mobile Service
Classic, Muscle & Luxury Autos
Ken Dickson • 602-788-9680
www.waxwerksdetailing.com

Aftermarket Enhancements

Gorilla Motorsports

Performance packages - superchargers - A/V
Custom interiors - wheels/tires - suspension
1425 S. Clark Drive • Tempe AZ 85281
408-507-0999 • www.gorillamotorsports.net

Vehicle Diagnostics

AutoXray

EZ-Scan 6000 Automotive Scanner
www.obd2can.com

Auto Dealers

Aston Martin North Scottsdale

18088 N. Scottsdale Road • 480-538-4200

Audi North Scottsdale

18088 N. Scottsdale Road • 480-538-4000

BMW North Scottsdale

18018 N. Scottsdale Road • 480-538-3900

Lou Grubb Ford

8555 E. Frank Lloyd Wright • 480-991-3333

MINI North Scottsdale

18018 N. Scottsdale Road • 480-538-6464

Porsche North Scottsdale

18000 N. Scottsdale Road • 480-538-3850

Scottsdale Lamborghini

Raintree & Hayden Road • 480-483-9300

Van Chevrolet

8585 E. Frank Lloyd Wright • 480-991-8300

Auto Dealers - Specialty

Dream Machines

14825 N. 82nd St. Suite C • 480-951-9524

Gorilla Motorsports

Select line of vehicles restyled for performance
1425 S. Clark Drive • Tempe AZ 85281
408-507-0999 • www.gorillamotorsports.net

Motorsports of Scottsdale

The Finest Collection of Pre-Owned Luxury Autos
Raintree & Hayden Road • 480-483-9300

Scottsdale Lotus

8355 E. Raintree Suite 170 • 480-922-6242

Online Classic Car Classifieds

ClassicCars.com

Put your classifieds online at
480-460-8800 • www.classiccars.com

Racing Events

SCO Nights

Sport Compact Drag Racing
Every Thursday at Firebird Raceway
www.dragracing.com/sco

Phoenix International Raceway

602-252-2227 • www.phoenixraceway.com

High Performance Schools

Bob Bondurant School of High Performance Driving

Mention Code AZ803 for discounted multi-day
1-800-842-RACE • www.bondurant.com

Automotive Fine Art

Automotive Fine Art by Don Evenson

Private commissioned paintings in oil or acrylic
11259 E. Via Linda • Suite 100-185
Scottsdale AZ 85259 • 480-661-8410

Auto Spa / Convenience / Gas

Cobblestone Auto Spa & Market

SCOTTSDALE:

• Frank Lloyd Wright & Hayden • 480-596-1200
• 15111 N. Hayden Road • 480-561-2622

PHOENIX:

• Bell Road & Piestewa Parkway • 602-787-0035

CHANDLER - Opening in September:

• Alma School & Germann • 480-814-9274

SURPRISE - Coming soon!:

• Bell Road & Grand Avenue

Service & Repair

Airpark Auto Service

8115 E. Raintree • 480-998-1605

Greulich's Auto Repair

8180 E. Raintree • 480-483-8186

Motorcycle Dealers

Cycle-Moto

Aprilia - Ducati - Motoguzzi - Triumph
330 E. Southern Ave # 37 • Mesa AZ 85210
480-898-0559 • www.azsbk.com

Motorcycle Manufacturers

Aprilia Motorcycles - Scooters

www.apriliausa.com

Dan Gurney Alligator Motorcycles, Inc.

Dan Gurney's All American Racers, Inc.

2334 S. Broadway • Santa Ana CA 92707
714-540-1771 • www.allamericanracers.com

Kawasaki Motors Corp., U.S.A.

9950 Jeronimo Road • Irvine CA 92618
949-770-0400 • www.kawasaki.com

Triumph

385 Walt Sanders Memorial Drive
Newna GA 30265
678-854-2010 • www.triumph.co.uk

Information is derived from a variety of sources and may not be final or accurate; check all info. Listings do not necessarily represent any specific affiliation with nor endorsement by Arizona Driver magazine.



ment (VCM) contributing to the balance of the improvements.

Like the gas version, the Accord Hybrid comes equipped with many safety features, including driver and front passenger dual-stage airbags, driver and front passenger side airbags, side curtain airbags, traction control system, ABS brakes along with a remote entry with security system, theft deterrent system and a LATCH system for a child's seat.

The Hybrid has excellent performance for such an economical car. Testers are listing 0-to-60 mph times of about 6.7 seconds despite the extra 200 pounds gained from the electric motor and batteries. This extra weight makes for a slightly longer stopping distance and maybe a slight, really unnoticeable, handling handicap. The IMA and VCM systems create a little more noise, but Honda engineers have compensated by adding an active noise reduction system, which does a good job of muting the little extra noise.

The performance of the Accord Hybrid was very good and we certainly liked the fuel economy; however, the regenerative braking system felt a little rough while coming to a stop or while accelerating from a dead stop. We got used to it after a few days, but it certainly wasn't that way in the Civic; the Civic was absolutely seamless.

There is little not to like about the Accord Hybrid; it does everything very well. The only sacrifice we could see, other than the higher price, is the slightly smaller trunk: 11.2 cubic feet, versus 12.8 cubic feet for the gasoline version. Trunk space was lost to make room for the traction battery and its ventilation system. There also is no spare tire, but there is a small air compressor and a can of sealant for repairing flats.

But the bottom line of having a car that accelerates so well, while getting significantly better fuel economy is that it's like having your cake and eating it too. ■

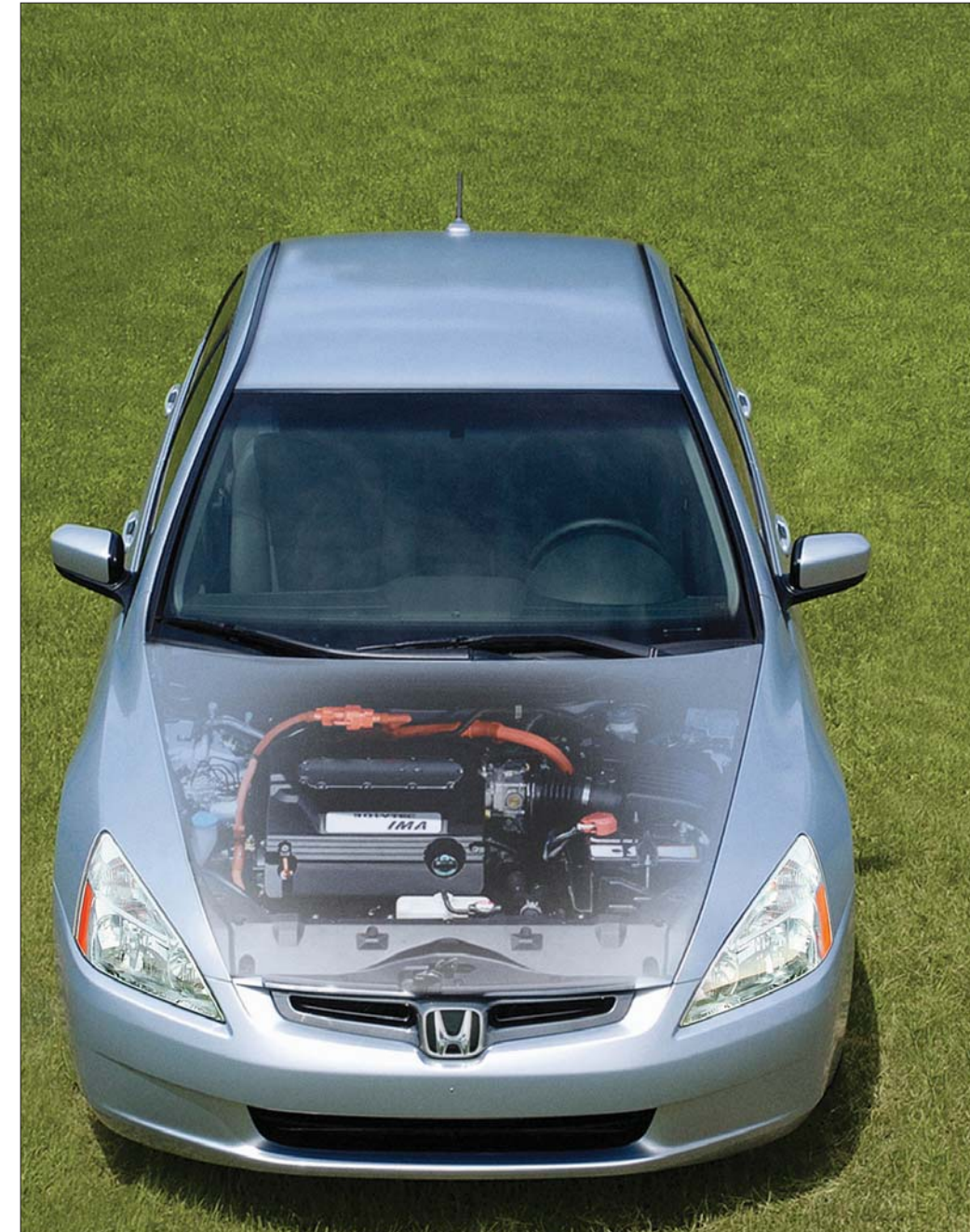

Clean energy

BMW's strategy

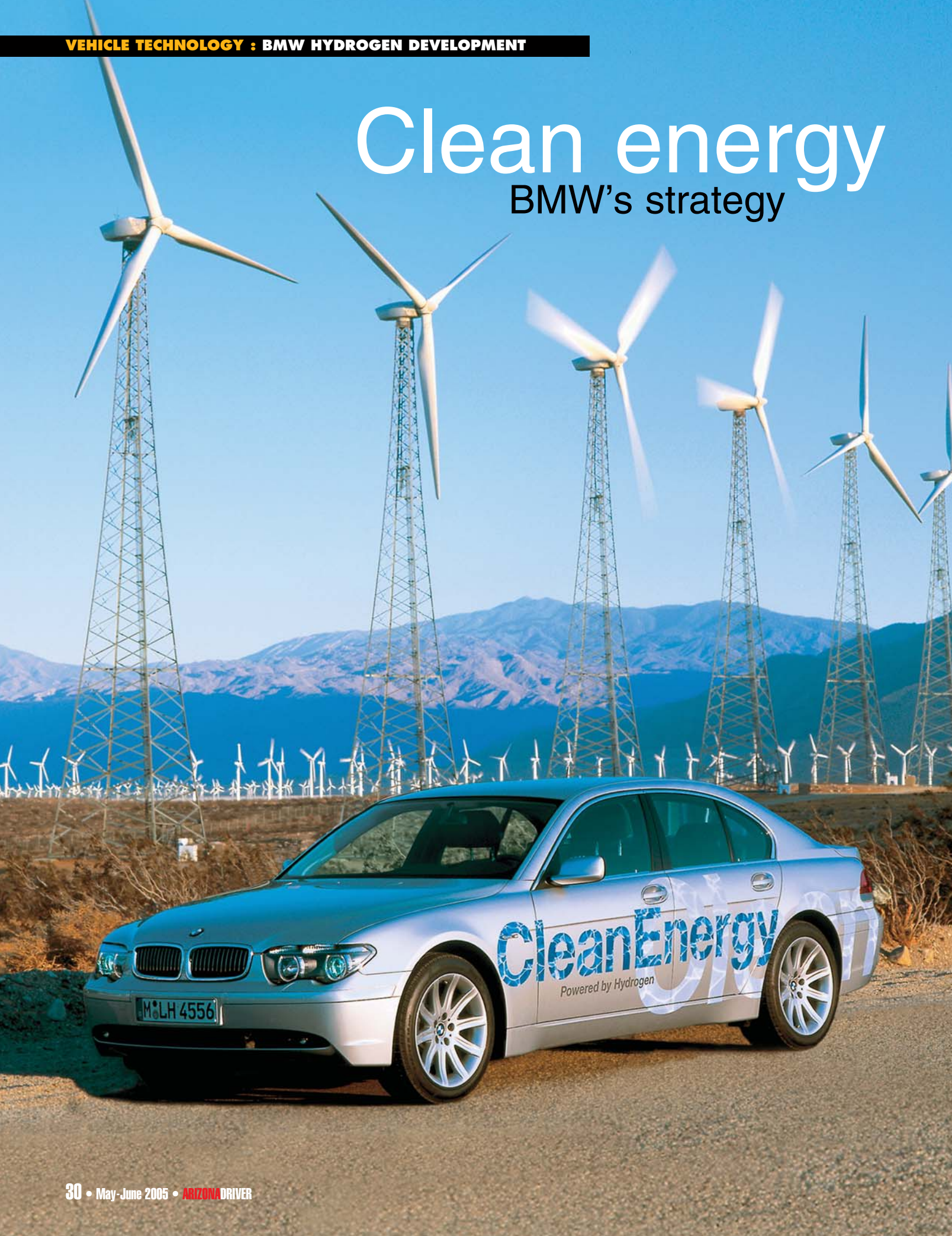

BMW V12 hydrogen internal combustion engine

The hydrogen age is here. Mankind's search for increasingly environmentally friendly individual mobility and independence from fossil sources of energy has led to a world-wide search for the fuel of the future. To ensure both environmentally friendly mobility and a smooth changeover to a long-term, sustained supply of energy, the fuel used must be fully sustainable, that is suitable for ongoing regeneration in a constant cycle. It must also fulfill a whole range of economic, qualitative and quantitative criteria. Researchers and experts around the world have begun to focus on one source of energy able to reach this ideal: hydrogen.

Hydrogen stands out clearly from fossil sources of energy by the simple, but all-important fact that in its recovery and use it can be embedded in a regenerating, natural cycle: whenever hydrogen is recovered through regenerating sources of energy such as solar, wind and water energy, it is indeed available in unlimited quantities and virtually without the slightest emissions. BMW claims to be the first car maker in the world to focus consistently on the medium- and long-term development of hydrogen use in their cars. The company has developed an all-around program: BMW CleanEnergy, the BMW Group's Energy Strategy. The long-term objective is to avoid emissions and use energy recovered in a regenerating process.

There are important reasons for this strategy: in July 1998 the Association of the European Automobile Industry (ACEA) made a commitment to the European Union to reduce the CO₂ emissions of all newly registered European cars to an average of 140 g CO₂/km by 2008. This equals a reduction in CO₂ emissions of 25 per cent against 1995 figures and amounts to average fuel consumption of just 47.1

mpg. A further reduction of CO₂ emissions by 14 per cent from 2008–2012 is also being considered; however, the industry says targets beyond 140 g CO₂/km cannot be achieved by vehicle-related improvements in fuel consumption alone. They call for the use of fuel either low in carbon or completely free of carbon. Enter hydrogen.

Depending on the drive system used, energy stored in hydrogen can be converted into two forms of energy for a car: either through a conventional combustion engine to convert energy directly into drive power, or through so-called "cold" combustion in a fuel cell generating electrical energy. BMW uses both options, focusing on the combustion engine for the actual process of driving a vehicle. The combustion power unit, given the sum total of its features, still offers the greatest number of benefits. At the same time, BMW sees the fuel cell as a source of energy supplying electric power to the on-board network in lieu of a conventional alternator, and offering brand-new options in air conditioning the car, as well as other comfort functions.

BMW aims to be considered an international leader in hydrogen technology, claiming 20 years of research and development to back this up. Their focus has included engine technology, but also recovery, storage and transfer of hydrogen into the car itself. Hence, the BMW Group is consistently promoting the introduction of hydrogen as a source of energy, establishing partnerships with other companies in developing components and technologies, and sensitizing both decision-makers in politics and the energy industry to the need to start the actual process of implementation now.

KEEP RIGHT >>

Hydrogen – the World's Most Common Element

Hydrogen, designated by its chemical symbol H, is the most common and, at the same time, the lightest element in the universe. Forming part of water and all organic compounds, it is part of the biological cycle and therefore fully compatible with the environment.

Hydrogen can be stored in gaseous form or as a cryogenic fluid and is relatively easy to transport. A non-toxic colorless, odorless gas, hydrogen is combustible and has approximately one-quarter the calorific value of gasoline in its liquid phase (in terms of volume). By weight, though, liquid hydrogen has almost three times as much energy as gasoline. Combustion of hydrogen generates water (H₂O), but no carbon dioxide (CO₂). Given all its properties, hydrogen, in the opinion of experts, has the potential to become the fuel of the future.

In nature hydrogen is virtually non-existent in its pure form outside of compounds. It is found most frequently in water, in various forms of hydrocarbon, and in other chemical compounds. Therefore it always requires a conversion process to be used for energy generation.

Currently more than 600 billion cubic meters of hydrogen are recovered worldwide each year. This hydrogen comes, for example, from the reformation of natural gas, from the production of coke or electrolysis of chlorine alkali, a process which generates hydrogen as a by-product. Annual production of hydrogen in Germany amounts to approximately 30 billion cubic meters.

Half of the hydrogen recovered in this way is required for synthesizing ammonia used for the production of artificial fertilizer and for the synthesis of plastics. A quarter of the ammonia serves for processing petroleum, and the final quarter is used for synthesizing methanol, an alcohol used in the textiles, dye, and plastics industry, and is also applied in a large number of metallurgical production processes.

Production: How Hydrogen is Recovered

Hydrogen may be recovered in various ways and through various processes crucial to the overall ecological balance of hydrogen as a fuel. The processes applied most frequently today use fossil sources of primary energy:

- ▼ Reformation of natural gas, liquid gas, and naphta
- ▼ Partial oxidation of heavy oil
- ▼ Gasification of coal
- ▼ Pyrolysis of coal to produce coke
- ▼ Reformation of gasoline

None of these offers a long-term, sustained alternative: First, they are based on finite raw materials and sources of energy; second, undesired substances such as carbon dioxide are released in the processes involved.

Simple, effective, clean: electrolysis.

Electrolysis is the most promising method for recovering hydrogen, using electric power to recover hydrogen from water in virtually unlimited quantities. The principle is straightforward: Two electrodes dipped into a water bath are subjected to a flow of direct voltage. Positively charged hydrogen ions (cations) gather in this process around the negative cathode; oxygen ions (anions) move to the positive anode.

Hydrogen gas generated in this process is retained, as is – where required – the gaseous oxygen. This may be done in various ways:

- ▼ through alkalic electrolysis
- ▼ through membrane electrolysis
- ▼ through alkalic high-pressure electrolysis
- ▼ through alkalic high-temperature electrolysis

The highly developed process of alkalic electrolysis is currently the most environmentally-friendly and economical production method among these processes. However, electrolysis makes sense in ecological terms only if the electricity used for the fission of water is obtained from regenerating sources of primary energy.



Free and unlimited: solar energy.

Large-scale generation of electric power by way of solar energy, using the power of the sun to recover hydrogen, is a key factor in finding a global solution for the future. The sun offers the largest potential of renewable energy, transmitting as much energy to the Earth in one hour as mankind consumes worldwide in one year: The solar energy at our disposal each year adds up to approximately 1.1 billion terawatt hours (TWh), roughly 10,000 times the current annual consumption of energy by mankind as a whole.

One way of converting this energy into electric power is through the use of solar cells generating electricity directly in the process of conversion. To try out such scenarios, the BMW Group played an active role from the beginning in the Solar Hydrogen Project in the small Bavarian town of Neunburg vorm Wald. Here, in cooperation with other companies, researchers examined the photovoltaic generation of hydrogen and its use for various purposes.

Re-growing raw materials may also be used instead of fossil carbon compounds as input for recovering hydrogen. Using biomass as the source of energy for regenerating hydrogen, the processes applied are unique in two respects: First, they are the only option to recover hydrogen directly from a regenerating source of primary energy. Second, biomass is generally regarded as almost neutral in terms of CO₂, since, through photosynthesis, plants take up the same amount of carbon dioxide from the air as they emit themselves when being processed.

Hydrogen can be recovered from biomass either through gasification or fermentation or through other biological processes. For ecological reasons numerous experts claim that hydrogen should only be recovered from waste biomass, and not from energy-bearing plants.

Studies state that in Europe hydrogen recovered from biomass has the potential to substitute approximately 30 per cent of the total amount of fuel generated in conventional processes. The assumption made in this case is that all the biomass available, including the cultivation of energy plants, is used exclusively for the production of fuel for road

traffic. But since biomass is also used for stationary purposes in the production of electricity and heat, its real potential for substitution is in the region of 15 per cent.

Hydrogen Storage-Distribution Infrastructure

Unlike electrical energy, hydrogen may be stored in large amounts, generally either in gaseous or liquid form. This provides the option to use electrical energy generated by solar, hydro or wind power for the fission of hydrogen and, going beyond current practice, to subsequently store the hydrogen recovered in this way.

Very large amounts of hydrogen are stored in so-called gasometers, medium quantities are kept in gaseous form in pressure tanks at approximately 30 bar. Small amounts, in turn, may be filled into pressure cylinders made of steel or carbon-fiber-reinforced composite materials up to a pressure of 400 bar. New tank systems able to withstand pressure of up to 700 bar are currently being examined.

Hydrogen can be stored in liquid form at a temperature of –253 °C. Since this kind of storage, as opposed to the storage of hydrogen in gaseous form at 700 bar, provides 1.78 more energy density per unit of volume, BMW advocates the use of liquid hydrogen for storage in the vehicle: The more energy one can take along within an existing tank of given capacity, the longer the range of the vehicle. To achieve the same energy density as liquid hydrogen, gaseous hydrogen would have to be compressed and stored at a pressure of 1250 bar.

Another option is to store hydrogen in a hybrid reservoir, where the hydrogen is kept under pressure in metallic powder and then released again as required through the infusion of heat. Hybrid reservoirs are able to take up approximately 2 per cent of their weight in hydrogen, which is not enough for use in a motor vehicle.

One more option being examined is the storage of hydrogen in nano-fiber structures or alانات (= chemical hydrogen compounds). Should these technologies prove viable, they would indeed open up new perspectives for the storage of hydrogen energy.

Pipeline, ships and trucks already standard

There are already pipeline networks in regions with a high concentration of chemical plants and companies for the long-distance transport of gaseous hydrogen. In principle natural gas pipelines are also quite suitable for this purpose, provided they meet the necessary technical requirements.

Hydrogen is also well-known in cities: light gas used in the past was a synthesized gas made up of 50 per cent hydrogen. In many cities this gas was used for purposes such as street lighting until well into the second half of the former century.

Intercontinental transportation of hydrogen is also a routine procedure these days, with the technical solutions required being largely in place. And since liquid hydrogen takes up only about one-tenth of the volume of gas compressed to 30 bar, ships and trucks are designed to carry cryogenic hydrogen. As in the case of nitrogen, oxygen or argon, the tank systems used in this case are high-vacuum-insulated double-jacket tanks.

Filling Your Tank

A basic prerequisite for broad-scale introduction of hydrogen as fuel is a tank-filling system as easy to use as the system we have today. This applies both to cryogenic, liquid hydrogen and to gaseous hydrogen under high pressure.

The BMW Group advocates the use of liquid hydrogen. The main reason for this decision is that the energy density of liquid hydrogen relative to the tank system is almost twice that of gas compressed to 700 bar, reaching a level of almost 2.5 kilowatt hours per liter.

BMW is developing a tank system allowing vehicles to be filled up with liquid hydrogen virtually just as fast, with no loss and no danger of any kind, that is with the same convenience and efficiency as in the case of gasoline or diesel. To offer the customer optimum comfort and

KEEP RIGHT >>

convenience, this tank-filling system is already in use at the world's first public "robotized" filling station for liquid hydrogen at Munich Airport. In April 2004 the project partners responsible for installing and operating this filling station were able to look back at five years of experience, so far filling more than 30,000 liters of liquid hydrogen into various vehicles in more than 600 operations.

The procedure is very straightforward: as at any other filling station, cars running on hydrogen drive up to the fuel pump located in the public area of Munich Airport. Then the driver initiates the fully automatic tank-filling process. While the tank is being filled up – which takes roughly as long as a conventional tank-filling process with gasoline or diesel – the driver in theory need not even get out of his car, since he is identified by his tank card or by electronic remote control. Liquid hydrogen at a temperature of -253°C is subsequently able to "rain" into the tank, hydrogen gas in the tank condensing on the droplets via the liquid phase and thus reducing the partial pressure of the hydrogen gas. As a result, absolutely no hydrogen is lost in the process of filling the tank.

In terms of the operations involved, the process of filling the tank manually is again virtually exactly the same as at a conventional filling station. By and large, the system differs only in terms of the pressure- and low temperature-proof connector taking the place of the usual pump nozzle: To fill up the tank, the driver places the connector on the tank filler pipe and locks it in position, enabling the hydrogen to "flow" in.

Crash tests with tanks for liquid hydrogen

BMW has conducted a comprehensive range of tests examining various accident scenarios and determining how liquid hydrogen tank behaves in the process. One procedure was to destroy full tanks under high pressure after deliberately blocking their safety valves.

In a further series of tests, vehicle tanks filled with liquid hydrogen were subjected to various fire conditions in a special test area: In the process the tanks were surrounded by flames at a temperature of almost 1000°C or approximately 1850°F for up to 70 minutes. Again, the tanks did not present any problems, the evaporated hydrogen slowly escaping through the safety valves in a smooth, almost imperceptible flow of gas. In the last series of tests, car tanks containing liquid hydrogen were deformed and seriously damaged by hard, solid objects. None exploded.

Liquid hydrogen is always cryogenic

Liquid hydrogen inside the tank of a car warms up in a "natural" process. The pressure inside the tank thus increases in the course of time until a limit currently set at 5.5 bar, the maximum pressure allowed in a tank

for liquid hydrogen. Under higher pressure, gas is able to escape in a controlled process through a spillover valve in a process comparable to the evaporation of gasoline from a conventional car tank when parked in bright sunshine. Currently it takes about one day for the fuel in a hydrogen tank to reach a pressure of 5 bar with the engine not running. And whenever the car is driven in the meantime, pressure decreases and the loss of hydrogen during extended standstill periods may be avoided altogether.

Hydrogen Drive Technology

BMW is the first carmaker in the world to start series development of a hydrogen car. In the words of Professor Dr. Burkhard Göschel, Board Member BMW AG for Development and Purchasing, "we will start delivering hydrogen cars to customers during the production cycle of our current BMW 7 Series".

BMW has been examining engines and vehicles for the use of liquid hydrogen since 1978. On 11 May 2000 BMW became the first car maker in the world to present a demonstration fleet of 15 hydrogen-powered sedans, in this case the BMW 750hL. The vehicles run by BMW have proven their qualities in everyday use, covering more than 170,000 kilometers.

In 2001 and 2002 some of these vehicles accompanied the BMW Group's CleanEnergy WorldTour. Visiting five major world cities, the BMW Group invited representatives of political life, the world of science and the media to attend special events held during the WorldTour. And the positive response shown by this international audience made the CleanEnergy WorldTour a great success.

Dual-mode drive for practical benefits.

Using current technology, only the combustion engine offers the advantage of being able to drive in a dual mode, that is on both gasoline and hydrogen. This serves to bridge any gaps in supply arising in the process of establishing and building up a network of hydrogen filling stations.

Intelligent combustion avoids nitric oxide

Sophisticated engine technologies are able to avoid the generation of undesired by-products in the combustion process. Above 1700°C or 3100°F , nitric oxides (NOx) may be generated in the combustion chamber with-out hydrogen being involved in the process.

To drastically reduce NOx emissions, BMW's engineers are pursuing a special operating strategy: As long as the engine is running under part load, load management, as with a diesel engine, is based on the concept of quality control, meaning that the engine is run in the lean mode with an air surplus ($\lambda > 1.7$) and with the generation of NOx emissions being kept to a minimum. As

a result, there is no need for any subsequent treatment of exhaust gas.

Whenever the engine is required to develop substantial power, engine load is based on quantity control, as in a gasoline engine: In this case the engine runs on a stoichiometric mixture ($\lambda = 1$) which, while generating NOx emissions, remains significantly beneath the SULEV limit through subsequent treatment of emissions. Fast electronic engine management and flexible valve control enable the engine to switch from one of these operating modes to the other virtually no delay.

Engine with potential efficiency of 50 percent

BMW is not short of ideas for further development. One additional option, for example, is to boost engine power by a turbocharger when operating with external fuel/air mixture formation. A combination of direct hydrogen injection and turbocharging, in turn, serves to further increase the engine's degree of efficiency while at the same time boosting engine output over that of the hydrogen concept engine, in this way raising the specific output of such a hydrogen engine to the same level as that of a petrol engine. BMW's Research Division is working on a hydrogen engine seeking in the long-term to achieve an effective degree of efficiency of 50 percent with the engine running at its optimum point. This demanding objective is to be reached by optimizing the combustion process and capitalizing in this way on the excellent combustion properties of hydrogen (low degree of activation energy required, high rate of flame propagation).

Crash tests with hydrogen cars

Complete cars, not only fuel tanks, must prove their high standard of safety. BMW hydrogen cars are already being examined in the usual crash tests such as head-on offset collision at an impact speed of 64 km/h, the standard rear-end collision with 100 and 40 per cent overlap, as well as a side-on collision at the car's most vulnerable point on the filler pipe leading to the fuel tank. And the BMW hydrogen car already meets all of these requirements in full. Indeed, in the words of the TÜV South Germany Technical Inspection Authority, "the hydrogen car is at least as safe as a conventional gasoline-powered car".

Feeding electricity to the on-board network

BMW's hydrogen concept also involves the use of a fuel cell, the so-called APU Auxiliary Power Unit. In this case, a PEM Polymer Electrolyte Membrane supplies electric power for the on-board network. While a conventional battery has to be charged by an alternator, this system operates independently of the engine and is fed with energy from the hydrogen tank. Even when the engine is not running the APU allows the driver to use the air conditioning or heating. And an

Auxiliary Power Unit not only supplies three times more power than an alternator, but also restricts this supply of power to the actual period of use, meaning that power is only supplied when actually required, whereas with conventional technology the engine drives the alternator all the time.

Applying this saving to conventional gasoline fuel, this means a reduction of fuel consumption by one liter per 100 km in city traffic. And if the coolant pump, oil pumps, brake servo and by-wire applications are also supplied with electric power in this way, a fuel cell is able to reduce fuel consumption to an even greater extent. Last but not least, the "drain" of power from the engine is more than 10 kW lower, this additional power then being available to drive the vehicle.

Molded tank replaces conventional cylinder

So far cylindrical tanks have been used in all cases to store liquid hydrogen, since currently they are the only tank configuration able to meet the great demands made in terms of insulation and safety. But development engineers look optimistically into the future also in the area of tank technology, focusing on molded hydrogen tanks making perfect use of the space available within the body. The objective is to integrate the hydrogen tank perfectly into the vehicle, thus offering the customer the usual space and convenience he wishes to enjoy inside his car.

Joint Ventures

CleanEnergy Partnership (CEP): Thorough test operation and hydrogen trials in Berlin.

To promote hydrogen technology in Germany along straightforward, practical lines, the BMW Group joined forces with Aral, BVG, DaimlerChrysler, Ford, GHW, Linde, Opel, and MAN in June 2002 to form the CleanEnergy Partnership or CEP for short. Established for a project term scheduled up to the year 2007 and with a budget of Euro 33 million, the CEP forms part of the German National Sustainability Strategy and is supported by the German Federal Government. It demonstrates technologies pointing into the future and presents the technical and economic prerequisites for the use of alternative fuel in road traffic.

Fluid/gaseous filling station construction

One of the key activities of the CEP is to build and operate a hydrogen filling station under regular conditions. Integrated in the everyday operations of a conventional filling station, this hydrogen filling station will be opened in autumn 2004. Apart from gasoline and diesel fuel, customers are able to fill their tank here with two types of hydrogen: compressed gaseous hydrogen (CGH₂) and liquid hydrogen (LH₂). The BMW Group favors the latter for reasons of handling and the range the car is able to cover.

Gaseous hydrogen produced locally

Gaseous hydrogen is produced locally at the filling station by means of pressure electrolysis virtually free of emissions. This technology has been developed for local production of a hydrogen energy supply with a high degree of purity. The principle is simple, water being split under pressure by direct current into its two elements hydrogen and oxygen. The compact facility used for this purpose is designed for fully automatic, ongoing and safe operation.

Tank trucks delivering liquid hydrogen

Liquid hydrogen is produced at a central location and delivered by tanker trucks. At the filling station the cryogenic hydrogen is stored in a highly insulated double-jacket 10,000-liter reservoir. Since evaporation pressure is reduced every time hydrogen is pumped into a car, the loss of hydrogen and the cooling operations required are kept to a minimum. This supply of liquid hydrogen also serves as back-up for the

KEEP RIGHT >>



supply of gaseous hydrogen: Should the supply of compressed hydrogen run low, liquid hydrogen can be converted into gaseous hydrogen to set off any bottlenecks in the supply process.

TES Transport Energy Strategy

No single company will be able to produce hydrogen as the fuel of the future all by itself. Precisely this is why the BMW Group, acting as a pioneer, has initiated various joint ventures: The TES Transport Energy Strategy Project started in May 1998 with the support of the German Federal Government and now comprising Aral/BP, the BMW Group, DaimlerChrysler, MAN, Opel, RWE, Shell, TOTAL and VW.

The objective of this initiative is to develop a common strategy for the introduction of alternative energy and drive systems. Further fundamental goals are to make transport less dependent on petroleum, to preserve finite resources, to further reduce emissions such as CO₂, and to expand the initiative to the whole of Europe. These objectives are based on the vision of a crisis-resistant, sustained, environmentally-friendly and resource-preserving supply of energy which, in combination with a new generation of highly efficient vehicles, is intended to pave the way into a more ecologically-minded and economical world of mobility in future.

Further BMW partnerships and joint ventures

In the series development of the hydrogen car, the BMW Group is working with a network of partners in industry. Magna Steyr, for example, has already become a highly competent BMW partner in the development and supply of the hydrogen tank.

Within an open Development Consortium, the BMW Group has joined forces with General Motors in the development of a liquid hydrogen tank coupling to be established as a global standard.

This projected liquid hydrogen coupling is based on the Draft Directive of the European Integrated Hydrogen Project (EIHP) serving in turn as the basis for compiling the future ECE Directives for Hydrogen-Drive Vehicles (ECE = Economic Commission of Europe of the United Nations). The actual process of developing the coupling is being conducted with the support of Linde and Walter, two specialist companies in this area.

BMW CleanEnergy Partnership in the US

The U. S. Department of Energy has awarded a grant to a partnership, which includes BMW and is led by Air Products and Chemicals, Inc., for a combined research project titled "Controlled Hydrogen Fleet and Infrastructure Demonstration Project". The goal of the project is to study hydrogen as a fuel in real-world driving conditions. This 5-year program

will use Federal funds, as well as donations from partnership members, to finance construction and testing of 24 hydrogen filling stations in California. Due to the nature of the project, the stations will vary from using renewable resources such as wind power to using a hydrogen pipeline. Some stations will be fixed; others will be relocatable.

Partnership members Toyota, Honda and Nissan will contribute a total of 65 fuel-cell powered vehicles to the project. BMW, as the leader in hydrogen internal combustion engines will provide up to 15 7 Series cars, the only test vehicles using proven internal-combustion engines.

Entering Everyday Life

The 2001/2002 BMW CleanEnergy WorldTours were one of several initiatives taken by the BMW Group to establish a greater acceptance of hydrogen and sensitize the public to this essential issue. In the "H₂ – Mobility of the Future Project", BMW has been offering schools throughout Germany comprehensive learning material on CleanEnergy since 2001. This material comprises not only a special folder for the teacher, but also an interactive CD-ROM. The same material is also available in English and, as "Expert Knowledge on Hydrogen" in Mandarin. Last but not least, there is also a special version of this teaching material for young children at Primary Schools. The material is available from BMW Corporate Communications.

CleanEnergy in Deutsches Museum Munich

In its function as a founding member, BMW offers information on hydrogen mobility of the future in the Transport Centre of "Deutsches Museum" in Munich: Ever since spring 2003, the BMW CleanEnergy Project has been showing how hydrogen paves the way into mobility in future. In an entertaining presentation, visitors to the Transport Centre are made acquainted with the recovery, distribution, storage and use of hydrogen. Interactive exhibits show how electricity gained from renewable energy serves to split water and generate hydrogen gas. The filling station of the future, in turn, demonstrates how cryogenic fuel is pumped into the tank of a car. And naturally the "heart" of the whole concept is also presented at the Museum, a prototype of the world's first hydrogen production car, the BMW 7 Series.

A touchscreen enables the visitor to get acquainted with the technical highlights of the hydrogen car in greater detail, focusing on the engine, the tank and the supply lines all the way to the exhaust system. The range of teaching material is supplemented by the H₂ laboratory even accessible from the internet, together with films and graphics. All this gives the observer a good idea of the many benefits

of hydrogen and heightens awareness of the steps still to be taken by society to make the fuel of the future reality in our world.

Beijing Science & Technology Museum

In cooperation with the Beijing Science & Technology Museum, the BMW Group has organized a BMW CleanEnergy Exhibition in the process of enhancing public knowledge in this area. In its concept, the Exhibition follows the approach the BMW Group has already taken at "Deutsches Museum" in Munich, presenting the complete hydrogen cycle ranging from the initial production and distribution of hydrogen all the way to the process of filling the tank and actually using hydrogen in the car.

Bottom line: hydrogen widely accepted

The Institute for Mobility Research in Berlin has examined the attitude of the population in a comprehensive study, arriving at the conclusion as early as in the late '90s that hydrogen is already widely accepted.

Knowledge on hydrogen is still limited, particularly young people. Precisely here, therefore, the teaching material provided by BMW makes an important contribution.

A survey has shown that the image of hydrogen crucial to its acceptance is largely neutral: Although respondents subjectively believe that hydrogen involves greater risks in the operation of a vehicle than gasoline and diesel, they agree that hydrogen should replace conventional fuel in future. The introduction of hydrogen powering an all-round or high-tech vehicle would therefore speed up the process of acceptance. And the benefits of hydrogen technology in terms of society and personal use are seen above all in the area of environmental protection.

Alternatives: Other Alternative Drive Concepts Considered

Pursuing BMW's energy strategy, researchers and engineers have focused not only on the hydrogen combustion engine, but also on other alternative drive concepts, developing promising technologies in the process.

Hybrid drive

Hybrid drive seeks to set off the weaknesses of individual systems and add up various strengths by pooling different technologies. With this in mind, BMW took a significant step in this direction in 2003, integrating an electric motor in a BMW X5 Experimental Vehicle between the combustion engine and the transmission in order to support the conventional drive system in the process of acceleration. High-performance capacitors in this case provide the energy required.

This Experimental Vehicle not only showed a standard of response never seen before as well as an increase in torque to 1,000 Nm or

737 lb-ft at low speeds, but also enabled the vehicle to reduce fuel consumption by up to 15 per cent in the usual test drive cycle.

A concept imaginable in future is to install a compact "active transmission" integrating both the electric motor and the power electronics into the transmission and thus significantly reducing both the additional weight and the space required for the system. High-performance capacitors in the door-sills could provide a further benefit, offering far higher charge and discharge rates than a battery system. And last but not least, electrical intervention in the drivetrain might serve to optimize driving conditions in, say, stop-and-go traffic or when accelerating.

In the serial hybrid system the combustion engine, alternator, electricity reservoir and the electric motor connected to the drivetrain all operate in series following the flow of energy. This can optimize the combustion engine for operating conditions with the highest degree of efficiency, the engine starting only when the battery is not able to provide the amount of energy currently required.

The challenge facing the engineer is to keep the space required and the extra weight – both of which are greater mostly due to the additional battery – within reasonable limits. A further factor is that such a vehicle requires two drivetrains at least in part. And last but not least, complex interaction of the two sub-systems presents greater demands in the management and development of the vehicle.

Hence, there are two crucial arguments against hybrid drive: As an add-on solution it makes the vehicle not only heavier but also more expensive. All concepts for intelligent electrification are therefore nothing but a supplementary solution in the ongoing development of the combustion engine.

Electric drive

Electric drive is among the oldest alternative drive concept. It is free of gaseous exhaust emissions and is acknowledged as the most environmentally-friendly drive technology. But this is only the case if the electricity used is generated in a fully ecological process.

The BMW Group introduced an innovative concept for electric drive vehicles in the guise of the E1 as early as in 1991. In terms of its size and range, such a vehicle is suited above all for use in cities and densely populated areas where the inherent disadvantages of the electric motor are less significant: Unlike the combustion engine, the electric motor develops maximum power at low speeds, while at the usual speeds on the motorway it is far less dynamic and agile than a combustion engine.

Ongoing development of the electric car is moreover linked inseparably to battery performance and efficiency. Battery systems are

still quite inadequate in meeting the requirements made by a road vehicle in practical use. The conflict of interests between energy and power density remains unsolved to this day. While a high-temperature battery is able to store three times as much energy on the same weight as a lead battery, it does not provide the same power output as, say, a nickel metal-hydride battery. To cover a range of 125 miles, a battery would have to weigh approximately 1100 pounds.

A further drawback is the battery's inadequate rapid-charging capacity, meaning that "filling up the tank" would take the whole night. And the fuel cell serving as a chemical battery still calls for great concessions in terms of both weight and cost.

Natural gas drive

Natural gas consists mainly of methane (CH₄) and is very similar to hydrogen in its properties relevant to the vehicle. In comparison with a vehicle running on gasoline, the combustion of natural gas in the engine reduces the generation of carbon dioxide (CO₂) by approximately 20 per cent. But since the process of conditioning and distributing natural gas from the well to the filling station involves higher CO₂ emissions than the conventional provision and distribution of gasoline or diesel, the actual reduction of CO₂ in practice is only about 10–15 per cent versus a vehicle running on gasoline.

Starting in 1995, the BMW Group became the first European car maker to offer series production cars with natural gas drive able to run in a dual mode either on natural gas or gasoline. Indeed, the BMW 316 g running on compressed natural gas was one of the cleanest cars in the world, right from the start fulfilling the strictest emission limits coming into force in California in 2003.

Knowledge gained in the project nevertheless showed that natural gas drive lacks the appropriate long-term perspective: A vehicle running on natural gas still emits sizable amounts of carbon dioxide. A further point is that natural gas is a fossil source of energy subject to finite supply. And the need to establish a natural gas infrastructure complete with filling stations would make this an unfeasible alternative en route to hydrogen technology. With the market acceptance of the natural gas car also being limited, the BMW Group has decided to discontinue its production of natural gas cars, taking the direct step into the world of hydrogen instead.

Accordingly, the BMW Group is continuing this approach through the series development of the hydrogen car with a combustion engine and its consistent commitment to hydrogen as a sustainable source of energy for the future. ■

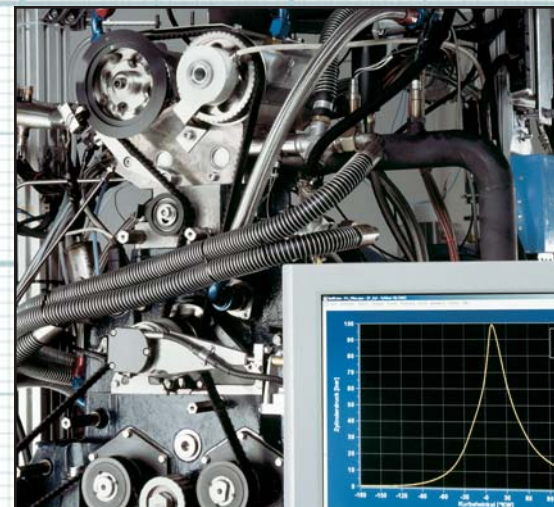

THE INSIDE TRACK: BRIEFS & RUMORS

■ **Toyota** will bring the FJ Cruiser to the US this fall. After a two-year study following the original showing at the 2003 Detroit show, officials have decided



Toyota FJ Cruiser

to produce the rugged two-door SUV for the US market. The production version has the retro look of the circ-1960 FJ-40 Land Cruiser.

■ **Ford** plans to "postpone" the production of the next SVT Lightning high performance truck until at least 2008 according to SVT spokesman Alan Hall. Rather Ford will concentrate on the SVT Cobra Mustang at this time.

■ **Ferrari** is building a special edition racecar to give to Pope John Paul II in recognition of his 26 years as leader of the Roman Catholic Church. The Ferrari is valued at \$485,000.

■ **Honda** is planning to add a new car one size smaller than the Civic early in 2006 as a 2007 model. Based on the Honda Fit, which is currently sold in Europe and Japan, the new car is designed to compete with the Toyota Scion, but Honda has no plans to develop a separate brand. Honda officials say the Fit will have a high content level so it would not need to be loaded up with options.



Honda Fit

A 1.5-liter four 4-cylinder will power the Fit and it's expected to have a sticker price in the \$12,000 range.

■ The next generation **Maserati** Coupe and Spyder will be based on a shortened version of the new Quattroporte platform. The designs will likely be introduced at the Frankfurt auto show in 2005. The Spyder is expected to get a new retractable hardtop and the Coupe will remain as a 2 + 2.

■ The upcoming **BMW** 1 Series sedan is scheduled to arrive stateside in 2006 powered by the same powertrain as the European versions. That means the top model, will have a 3.0-liter 258-hp

inline six-cylinder with a six-speed manual transmission. Zero to 60 mph acceleration times are expected to be in the 6.0-second range.

■ **Kia** will enlarge the Sedona minivan, when the next generation arrives this fall. The all-new Sedona will be 8 inches longer with a 6-inch longer wheelbase. New features include power sliding side doors with power windows, power-operated tailgate, adjustable pedals and a standard hidden third row seat.

■ **Volkswagen** has plans for a car to compete with the spectacular new CLS "four-door coupe" according to AutoWeek

magazine. It's expected to be built on a widened version of the next generation Audi TT chassis.

■ **Cadillac** is moving forward with plans to get into the ultraluxury sedan (ULS) business. General Motors vice chairman, Robert Lutz, is pushing the program that would create a \$100,000 plus ULS within the next three or four years. Lutz said the dramatic rear-drive Cadillac Sixteen shown at the 2003 Detroit auto show will not be built, but the car could have V-12 engine that GM is currently developing.

■ **Dodge** will drop the Neon compact sedan next year and replace it with an entirely new styling theme that resembles a five-door wagon or hatchback. The new vehicle will be called the Caliber if Dodge keeps the name used for the concept



BMW 1 Series

shown recently at the Geneva auto show. Chrysler Group CEO Dieter Zetsche said the Caliber will set the company apart by being a styling leader offering great functionality. It is being developed on the next-generation Mitsubishi front-wheel drive platform.

■ **Michelin** has developed a new airless tire system. They call the system the Tweel and the process involves a band of tread material positioned around flexible polyurethane spokes. The spokes and wheel would be molded as a single component with the outer tread added as a second component. Michelin says it could be 10 or 15 years before the system may find acceptance. The systems are currently being used on some prototype vehicles, construction equipment in Europe, wheel chairs in North America and in a few military applications.

■ **Pontiac** will discontinue building the Sunfire in June, leaving the company without an entry-level vehicle for at least 18 to 24 months, says Pontiac-GM Marketing Manager Jim Bunnell. The company has also announced it will drop the full-size Bonneville sedan.

■ Now you can buy the **Chrysler** Hemi à la carte. Chrysler will now be selling the 5.7-liter, 360-hp Hemi engine through its Mopar parts division dealers. The crate engines are designed to be utilized on a variety of aftermarket hot



Chrysler HEMI® engine

rod installations. Mopar is also planning to offer the original Hemi engines from the late 1960s in 426-, 472- and 528 cubic inch versions.

■ **Porsche** is expected to offer a new hardtop coupe this summer to fit in a price and size slot between the Boxster and the 911. The expected Cayman S will be based on the Boxster platform and powered by a 3.4-liter, 295-hp, 6-cylinder engine. The Cayman name comes from a species of crocodile known for its quickness and tenacity.

■ In addition to the planned 7-passenger Q7 sport utility planned for early 2006, **Audi** is adding a second SUV based on the A4 sedan platform. The Q7 will be an Audi designed version of the Volkswagen Touareg SUV, which will come with a V-6, V-8 and possibly V-10 diesel engine model.

■ With the devalued US dollar cutting into profits for imported makes, **Audi** is exploring the possibility of building a manufacturing plant in the US. BMW and Mercedes-Benz are also looking at expanding existing facilities.

■ **Nissan** plans to expand the sales volume of the CVT (Continuously Variable Transmission) to as many as 40 percent of the Nissans sold in the US by 2008. In 2004 the CVT penetration was only 6.3 percent or all the Murano production. Nissan has not yet indicated which models will get CVTs, but the Murano does share its platform and V-6 engine with the Nissan Altima, Maxima and Quest.

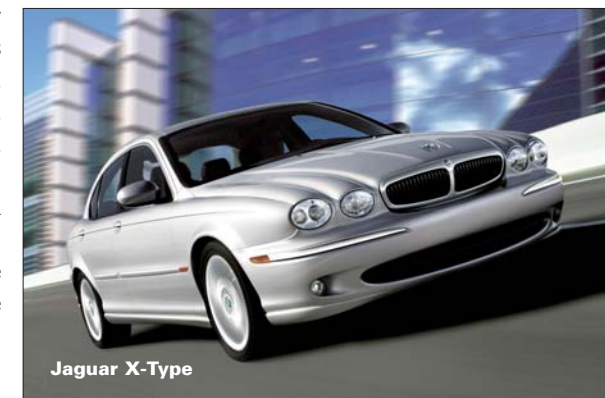

Jaguar X-Type

■ Add to the list of discontinued products the **Chevrolet** Astro and **GMC** Safari vans. The rear-wheel-drive body-on-frame and awd vans have been built for 20 years and have been virtually unchanged for years. The vans were popular for delivery outfits and for people who pulled a boat or trailer.

■ Watch for **General Motors** to start pricing new products at levels closer to anticipated transaction prices. For the last couple of years the company has relied on large cash bonuses and other incentives to make sales. Now they are hoping more realistic (and simpler to understand) pricing will do the trick.

■ **General Motors** said it will stop offering a Quadrasteer (drive by wire) four-wheel steering system. GM officials speculate the \$2,000 option (originally it was part of a \$4,495 option package) was more than buyers wanted to spend,



GM Quadrasteer

even though the system added greatly to the agility of the Chevrolet and GMC trucks. The company only sold 16,500 Quadrasteer equipped vehicles since the option became available in 2002.

■ **Ford** Development and Chief Technical officer, Richard Parry-Jones

recently said Jaguar will definitely have an all-wheel drive option on the upper level luxury models. He also hinted at a possible hybrid X-type high performance R version and a likely new overall direction for the X-Type.

■ **Mercedes-Benz** has officially ended its partnership with McLaren to produce limited edition high performance vehicles. Of the three vehicles planned for joint development, only the 200-mph \$400,000 SLR McLaren came to fruition. A Mercedes insider said the cars were too costly to be a solid business case.

■ **Rolls-Royce** Motor Cars Ltd. said it is exploring the possibility of building a lower price car to compete with the very successful Bentley Continental GT. At present BMW-owned Rolls-Royce only offers one car, the \$328,000 Phantom. It has approved the design of a convertible similar to the Phantom, which is planned for production in 2007.

■ **Isuzu** dealers will finally get a second product to sell in the US later this year, when a yet-to-be-named pickup arrives at dealers. A two-wheel-drive extended-cab pickup with a 2.8-liter four-cylinder and a crew cab with four-wheel drive and 3.5-liter five-cylinder engine will be offered. The 2006 truck, based on the Chevrolet Colorado and GMC Canyon, will be built in the US. ■

Briefs & Rumors is a summary of auto news from industry sources, trade journals and consumer magazines compiled for *Arizona Driver Magazine* by **BILL & BARBARA SCHAFFER** of *Auto Digest*.

This li'l pup has grown up

By Barbara and Bill Schaffer



The frosting on the cake? 5-year/60,000 mile warranty (10-year/100,000-mile powertrain), 5-year unlimited mileage roadside assistance package.

The new Kia Sportage has come a long way since it was first introduced in 1995. For 2005, after a hiatus, the Kia Sportage has been completely redesigned from the ground up. It's wider, longer, taller and more refined, making it a real contender to the more established brands.

When Kia first introduced the Sportage SUV, public response was so strong that surveys indicated the Sportage name was more recognizable than the Kia name. Along the road, Kia picked up an impressive list of awards. But after eight years without a significant overhaul, sales declined. In 2003 Kia added a larger SUV called the Sorento, and in an interesting move, stopped building the Sportage for a couple of years. This allowed the Sorento to get established in the market without being confused with the Sportage. Now two years later, the new Sportage is back, and it's impressive.

The sportier look of the new Sportage offers sleeker lines, giving it better aerodynamics for a quieter ride. Exterior lines are clean and simple, with a high nose, steeply raked windshield, long roofline with twin roof bars and a sloping D-pillar. The wheels have been pushed out to the corners making more interior room while achieving improved stability, handling and ride.

The more spacious cabin is easily accessible with wide-opening doors. A new "Drop & Fold" rear seat plus flat-folding front passenger seat gives buyers a large number of seating and cargo carrying combinations. Even with all seats occupied, the new Sportage can still handle three sets of golf clubs in the cargo area. The rear seatback can be adjusted by up to 18 degrees for added comfort, plus both front seats can be fully reclined after the headrests have been removed, meeting up with second row cushions for sleeping, if you found it necessary.

Kia engineers developed the Sportage from the platform and several of the chassis components of the all-new Spectra, to create a stiff, strong body and frame. The result is a solid-feeling wagon with low noise, solid ride feel and enhanced passenger protection. The structure is enhanced by the latest electronic aids like Electronic Stability Program, traction control, electronic brake distribution and anti-lock brakes.

Standard safety features on the Sportage include dual advanced front airbags, front seat mounted side airbags, front and rear curtain airbags, three-point seatbelts for all seating positions, side-door impact beams and the LATCH system for a child seat.

Shoppers can choose between models with a 2.0-liter, 140-hp four-cylinder

engine with Continuously Variable Valve Timing and a 2.7-liter, 173-hp DOHC V-6. The four-cylinder comes with a standard five-speed manual transmission, and an optional four-speed Sportmatic(tm), while the V-6 is only available with the Sportmatic. Both engines are available in either a front-wheel drive or full-time four-wheel drive configuration.

Both the entry-level LX and the upscale EX come in both 2-wheel and 4-wheel drive versions. Prices start at \$16,490 including delivery and go up to just under \$22,000 for a fully loaded EX 4x4. The best option, we think, is the luxury package that includes leather, heated front seats, AM/FM/CD/MP3 and cassette stereo, HomeLink remote system and more for just \$1,300.

We don't expect the Sportage to win any races, but it has plenty of power for the average driver, for passing and merging with freeway traffic. Acceleration times have been listed at just over 10 seconds, 0 to 60 mph. We averaged 22.5 mpg during our week in the Sportage, which is about in the middle of the EPA estimates of 19 mpg for city driving and 25 mpg on the highway.

We came away from our time in the Kia Sportage with a very favorable impression. It's solid and quiet, which appears to be a direct correlation to the good fit and finish,



both inside and outside. The controls are in a very basic and conveniently arranged allowing the driver's right hand to move between shifting, audio, climate and wheel with only a small amount of movement. Cabin features are very well thought out, with conveniences like a retractable hook on the passenger side of the console for a purse or litterbag. There are numerous storage spots, and drink holders are out of the way, mounted between the shifter and center console.

On road, the Sportage is satisfying to drive. It feels heavy and solid on the road, while maintaining the agility that's so appealing with a smaller SUV.

This is an exceptional vehicle at any price, but for the \$20,000 price tag on our test EX 4x4 with the luxury package, it's a steal! ■

Kia Sportage 4x2

STANDARD EQUIPMENT

16-Inch alloy wheels; Traction control; electronic Stability Program; Air conditioning; Sunroof; Power windows and locks; Heated outside mirrors; Trip computer; Keyless entry/Alarm system; Cruise control; Roof rails; Fog lights; AM/FM/CD/Cass. Audio; Leather package with heated front seats; Auto dimming mirror.

Base Price: \$19,999
Options:none
Freight:\$590
Price as Tested:\$20,589

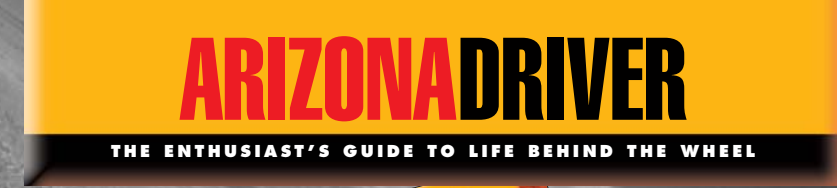

Where the roads are dry and the cars are slick.

Arizona Driver Magazine
 PO Box 13387
 Scottsdale AZ 85267
 480-948-0200

UPCOMING FEATURES

MINI Cooper S Cabriolet



If nothing says "performance fun" like MINI, then add the Cooper S level, and on top of that make it a cabriolet, and what do you have? Find out how much fun, next issue.

Honda Ridgeline



We've already met with the development engineers of this segment-busting pickup, and now we'll be driving it for a week. Stay tuned to see what's in store with Honda's pickup.

BMW Driver Training: Adventure Trainings and Adventure Trips



Winter Training: Pirouettes, Z4 Roadster "Topless" through Europe, X5 Adventure Trips, Nürburgring Nordschleife M3 Circuit Training and M5 "Taxi" —learning can be lots of fun!



